

BROCHURE
PRODUCTS - PRODOTTI



**DRY BULK STORAGE AND
HANDLING SOLUTIONS**



SCUTTI



SCUTTI S.r.l.



Was established in 1967 by Mr. Nicola Scutti, the company's early days were spent in focusing on manufacture silos for cement throughout the European market place, during the years the company has been characterized for harbour silos and dry bulk storage solution. In 1992, further to a large investment project the company enhanced its products range by including the production of tubular and trough screw conveyors, dust collectors, slide and butterfly valves.

High quality products, continuous investment plans and strong attitude to pay attention on specific client's needs made the company grow in few years and build a sales network extended over many countries in the world.

The competence of our staff and our long-term experience in the field enabled us to develop highly performing and warranted products to comply with specific enquiries with proper technical solutions.

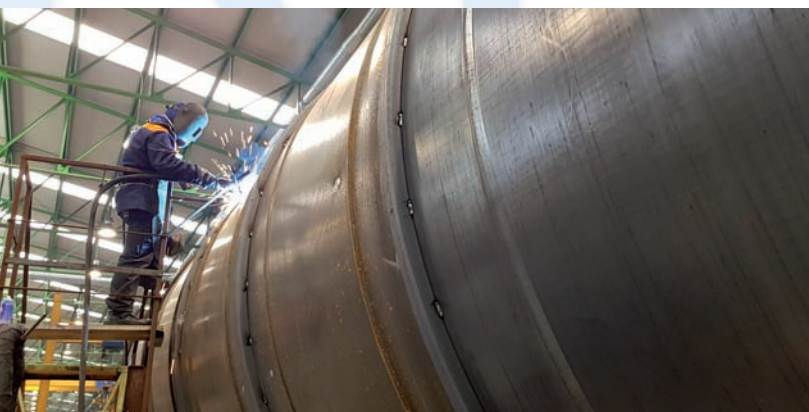

Fondata nel 1967 dal Sig. Scutti Nicola, dalla sua fondazione l'azienda opera nel settore degli impianti di stoccaggio, e per lunghi anni ha costruito soprattutto sili per cemento destinati al mercato europeo, distinguendosi da subito per le installazioni portuali ed i grandi stoccaggi.

Dal 1992 l'azienda ha ampliato la gamma dei suoi prodotti iniziando la costruzione di coclee trasportatrici, di filtri depolveratori, di valvole d'intercettazione e altri accessori. La qualità dei prodotti, i continui investimenti nel processo e la spiccata disponibilità dell'azienda ad adattarsi alle esigenze specifiche dei suoi Clienti, ha fatto sì che in pochi anni essa sia cresciuta fino ad essere presente in buona parte del mercato mondiale, dall'Estremo Oriente all'America del Sud: la nostra rete commerciale copre oggi molti paesi nel mondo, ed è in continua crescita.

La professionalità del nostro staff e la pluriennale esperienza sul campo ci ha permesso di sviluppare una gamma di prodotti di alte prestazioni e affidabilità in grado di soddisfare le esigenze di ogni specifico prodotto con la soluzione tecnica più appropriata.

INDEX

Indice



PAGES *Pagine*

CONTENTS *Contenuti*

01	Index <i>Indice</i>
02	Vertical Storage <i>Stoccaggi Verticali</i>
03 - 04	Telescopic Silos <i>Silos Telescopici</i>
05 - 06	Monolithic Silos <i>Silos Monolitici</i>
07 - 12	Paneled Silos <i>Silos a Pannelli</i>
13 - 16	Flat Storage <i>Stoccaggi Orizzontali</i>
17 - 21	Screw Conveyors <i>Coclee Trasportatrici</i>
22- 29	Dust Filtration <i>Filtrazione Polveri</i>
30 - 33	Silo Safety System <i>Sistema di Sicurezza Silos</i>
34 - 38	Dust Valves <i>Valvole per Polveri</i>
39 - 40	Accessories <i>Accessori</i>





**VERTICAL
STORAGE**

Stoccaggio Verticale

TELESCOPIC SILOS

Silos Telescopico

Ø 2.380 mm ST SERIES - SERIE ST

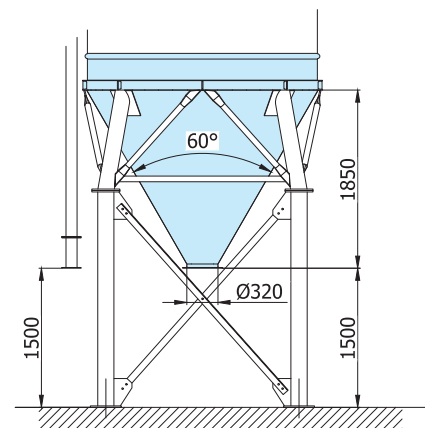
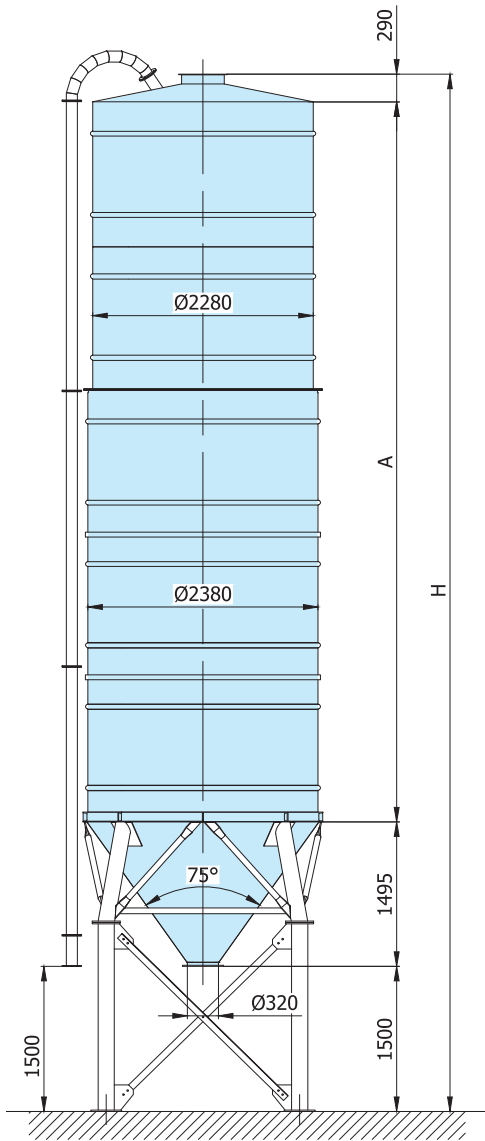

DIMENSIONS - DIMENSIONE (mm)

TYPE	m ³ ⁽¹⁾	Ton ⁽²⁾	A	H
ST 30	29	40	6000	9320
ST 37	36	50	7500	10820
ST 43	42	60	9000	12320
ST 61	60	85	13500	16820
ST 68	68	95	15000	18320

(1) Capacity is referred to silo's geometric volume.

Valore riferito al volume d'aria contenuto nel silo.

(2) Weight referred to Cement bulk density of 1,4 Ton/m³.

Valore riferito a cemento a densità 1,4 Ton/m³.



MONOLITHIC SILOS

Silos Monoblocco

Ø 2.380 mm SM SERIES - SERIE SM

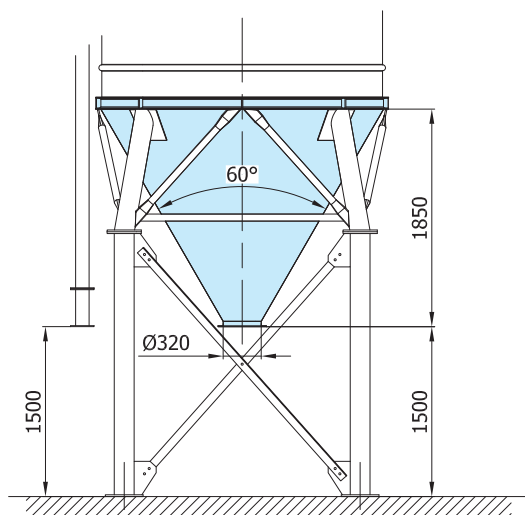
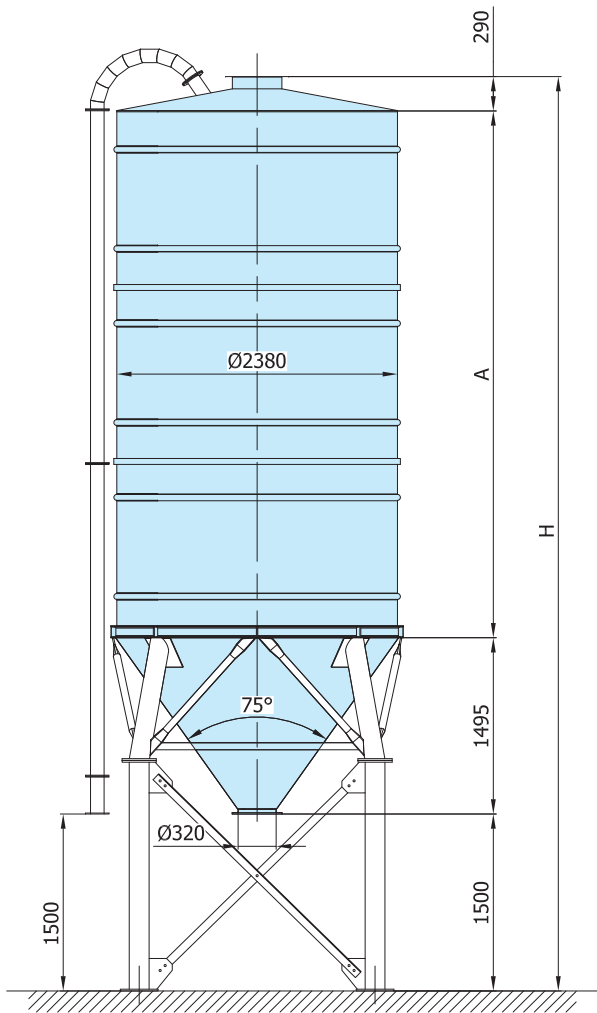

DIMENSIONS - DIMENSIONE (mm)

TYPE	m ³ (1)	Ton (2)	A	H
SM 23	23	30	4500	7825
SM 30	30	40	6000	9325
SM 37	37	50	7500	10825
SM 44	44	60	9000	12325
SM 50	50	70	10500	13825
SM 55	55	77	11500	14825

(1) Capacity is referred to silo's geometric volume.

Valore riferito al volume d'aria contenuto nel silo.

(2) Weight referred to Cement bulk density of 1.4 Ton/m³.

Valore riferito a cemento a densità 1,4 Ton/m³.



MONOLITHIC SILOS

Silos Monoblocco

Ø 3.000 mm SM SERIES - SERIE SM

DIMENSIONS - DIMENSIONE (mm)

TYPE	m ³ ⁽¹⁾	Ton ⁽²⁾	A	H
SM 65	65	90	9000	12555
SM 75	75	105	10500	14105
SM 85	85	120	12000	15555

(1) Capacity is referred to silo's geometric volume.

Valore riferito al volume d'aria contenuto nel silo.

(2) Weight referred to Cement bulk density of 1.4 Ton/m³.

Valore riferito a cemento a densità 1,4 Ton/m³.

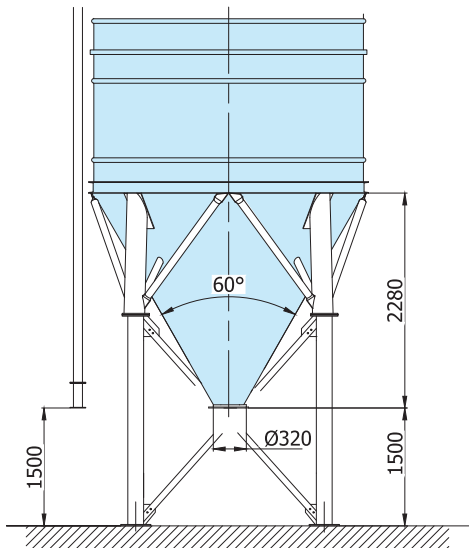
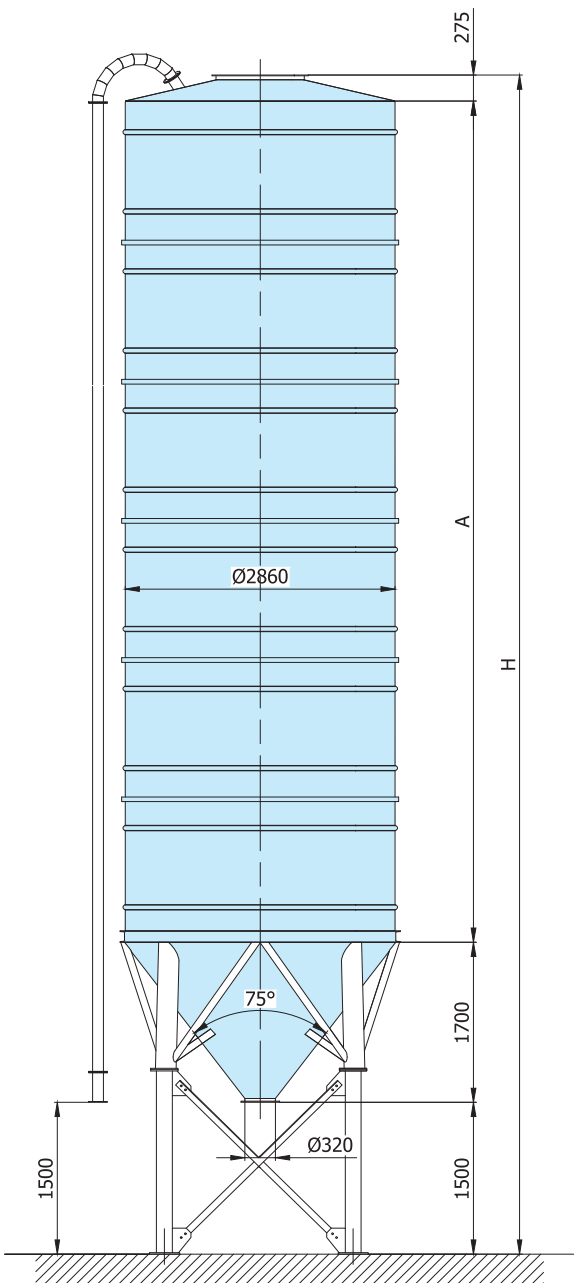

PANELED SILOS

Silos in Pannelli

Ø 3.500 mm SERIE SP - SP SERIES

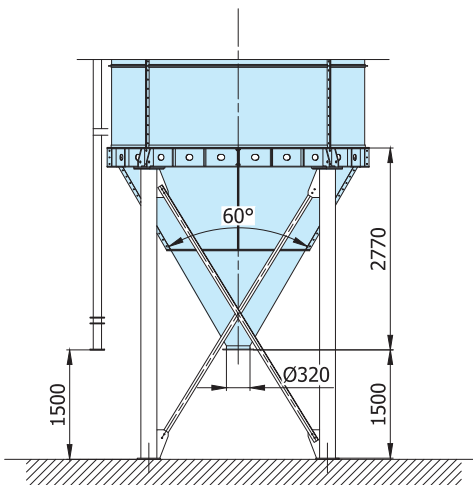
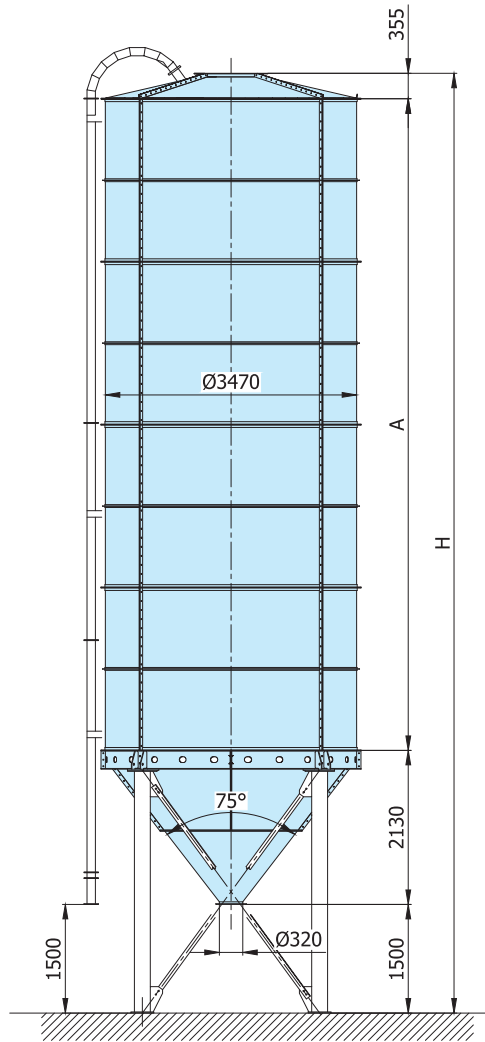

DIMENSIONS - DIMENSIONE (mm)

TYPE	m ³ ⁽¹⁾	Ton ⁽²⁾	A	H
SP 50	50	70	4500	8440
SP 70	70	100	6750	10690
SP 90	90	120	9000	12940
SP 110	110	150	11250	15190
SP 135	135	190	12500	17520

(1) Capacity is referred to silo's geometric volume.
Valore riferito al volume d'aria contenuto nel silo.

(2) Weight referred to Cement bulk density of 1,4 Ton/m³.
Valore riferito a cemento a densità 1,4 Ton/m³.

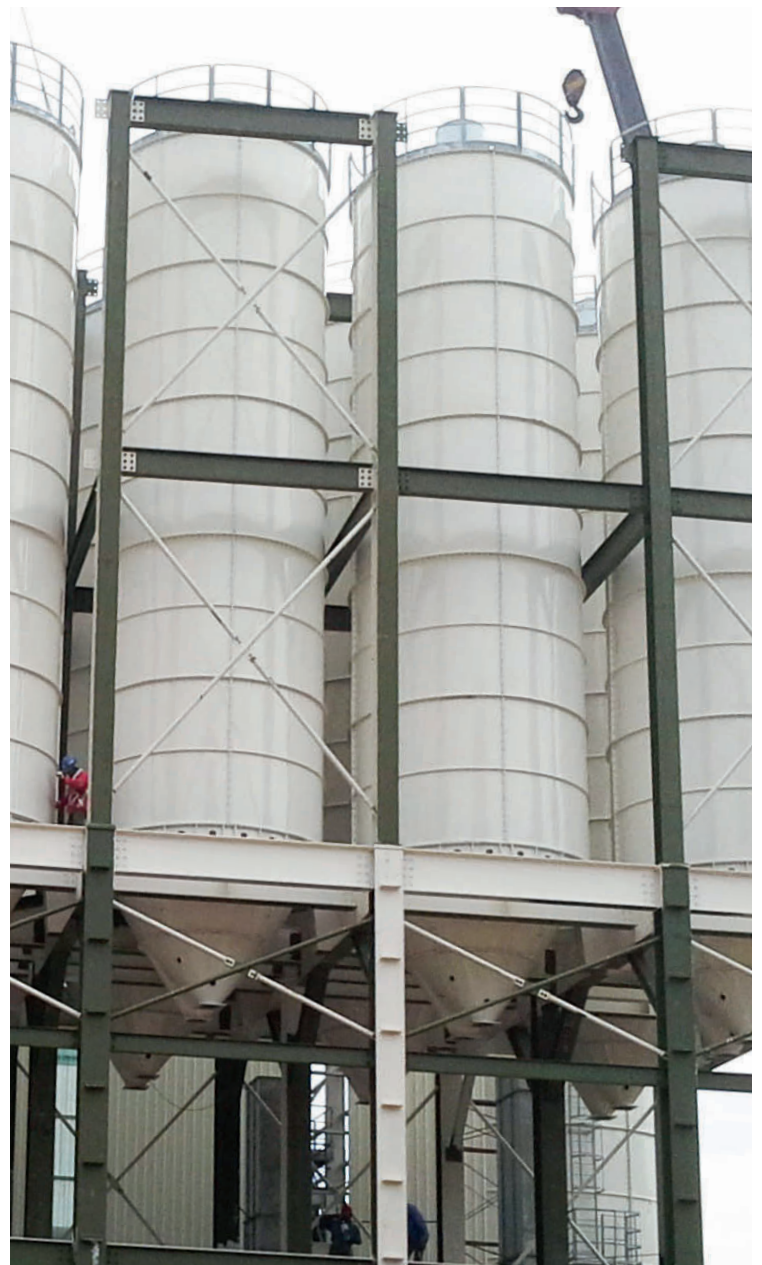

PANELED SILOS

Silos in Pannelli

Ø 5.000 mm SP SERIES - SERIE SP

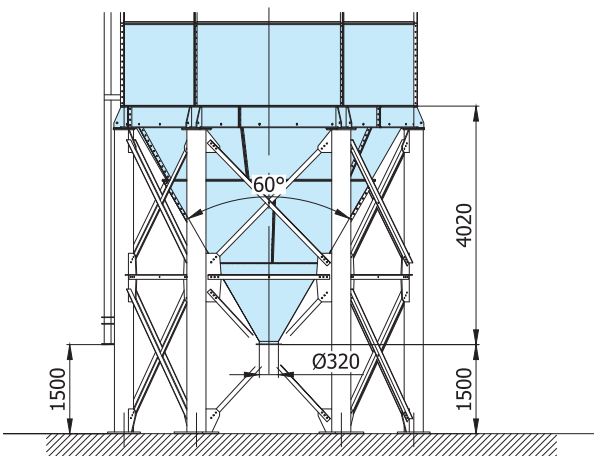
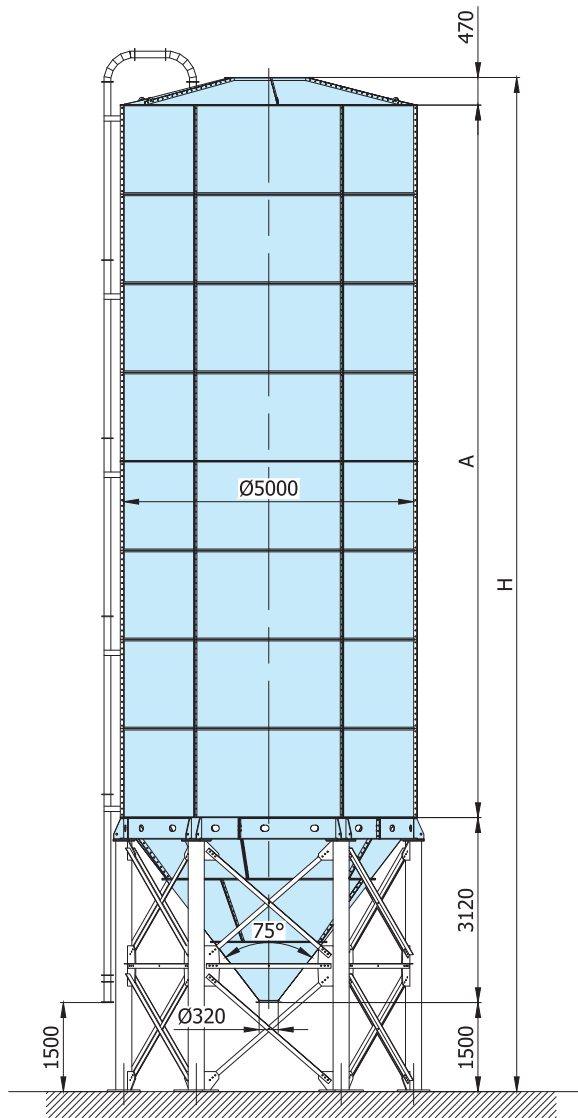

DIMENSIONS - DIMENSIONE (mm)

TYPE	m ³ ⁽¹⁾	Ton ⁽²⁾	A	H
SP 140	140	200	6000	11060
SP 170	170	240	7500	12560
SP 200	200	280	9000	14060
SP 226	226	315	10500	15560
SP 250	250	350	12000	17060
SP 275	277	385	13500	18560

(1) Capacity is referred to silo's geometric volume.
Valore riferito al volume d'aria contenuto nel silo.

(2) Weight referred to Cement bulk density of 1.4 Ton/m³.
Valore riferito a cemento a densità 1,4 Ton/m³.



PANELED SILOS

Silos in Pannelli

Ø 6.150 mm SP SERIES - SERIE SP

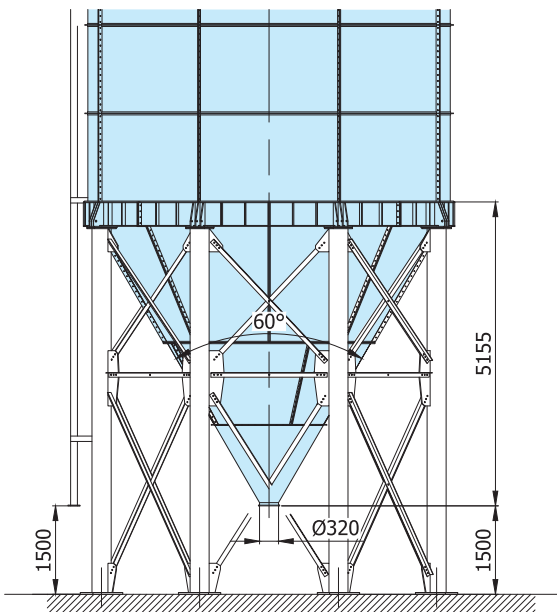
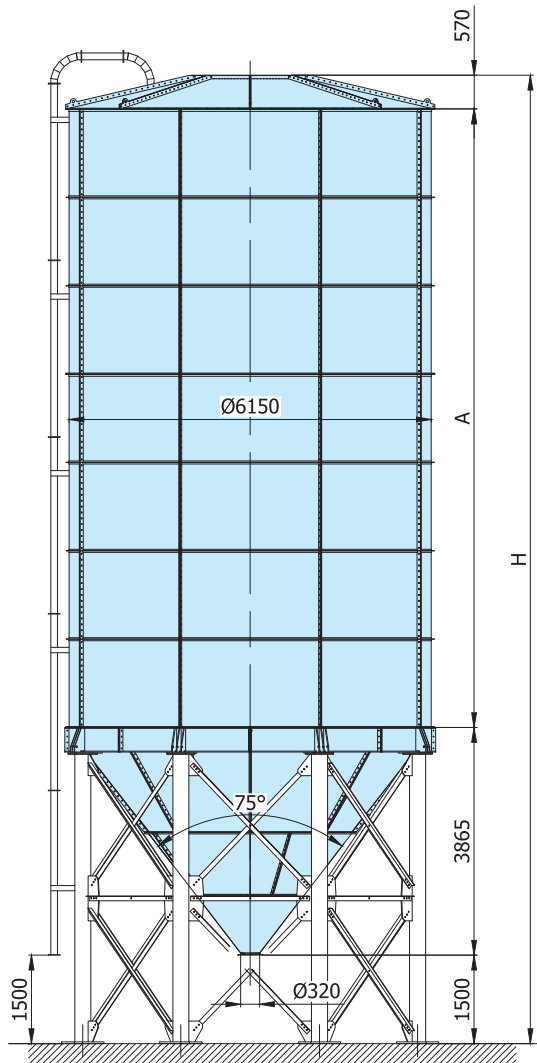

DIMENSIONS - DIMENSIONE (mm)

TYPE	m ³ ⁽¹⁾	Ton ⁽²⁾	A	H
SP 215	215	300	6000	11900
SP 260	260	360	7500	13430
SP 300	300	420	9000	14930
SP 350	350	490	10500	16430
SP 400	400	560	12000	17930
SP 450	445	625	13500	19400

(1) Capacity is referred to silo's geometric volume.
Valore riferito al volume d'aria contenuto nel silo.

(2) Weight referred to Cement bulk density of 1.4 Ton/m³.
Valore riferito a cemento a densità 1,4 Ton/m³.



PANELED SILOS

Silos in Pannelli

Ø 7.600 mm SP SERIES - SERIE SP

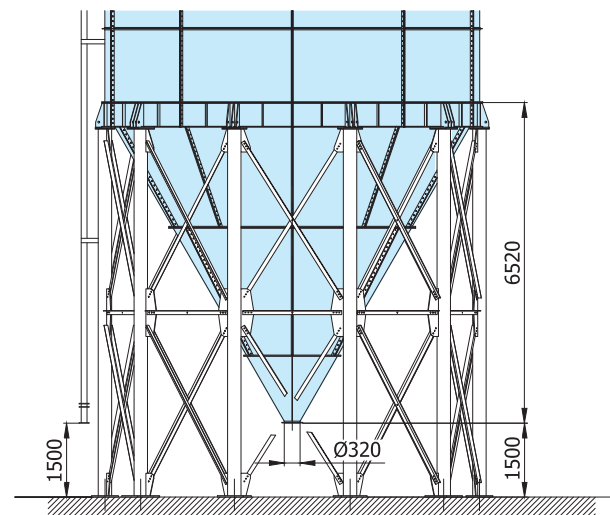
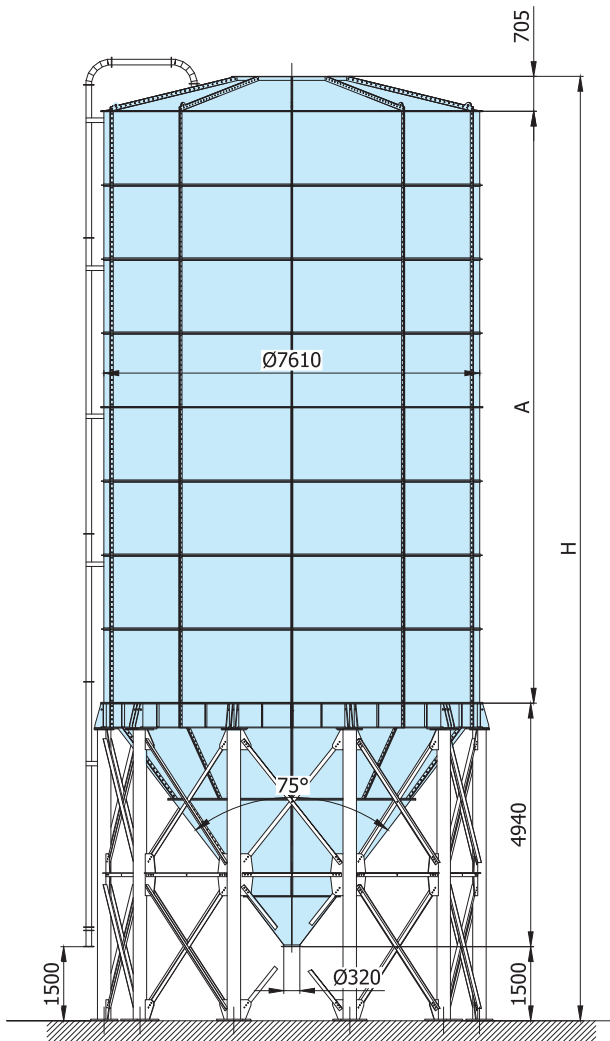

DIMENSIONS - DIMENSIONE (mm)

TYPE	m3 ⁽¹⁾	Ton ⁽²⁾	A	H
SP 355	355	490	6000	13140
SP 420	420	580	7500	14640
SP 490	490	680	9000	16140
SP 560	560	780	10500	17640
SP 630	630	880	12000	19140
SP 700	705	985	13500	20605
SP 770	770	1075	15000	22105

(1) Capacity is referred to silo's geometric volume.
 Valore riferito al volume d'aria contenuto nel silo.

(2) Weight referred to Cement bulk density of 1.4 Ton/m³.
 Valore riferito a cemento a densità 1,4 Ton/m³.



PANELED SILOS

Silos in Pannelli

Ø 9.500 mm SP SERIES - SERIE SP

DIMENSIONS - DIMENSIONE (mm)

TYPE	m3 ⁽¹⁾	Ton ⁽²⁾	A	H
SP 600	600	840	6000	14550
SP 710	710	990	7500	16050
SP 815	815	1140	9000	17550
SP 920	920	1280	10500	19050
SP 1000	1000	1400	12000	20550
SP 1100	1100	1540	13500	22050
SP 1240	1240	1736	15000	23550
SP 1350	1350	1890	16500	25050
SP 1450	1450	2030	18000	26550

(1) Capacity is referred to silo's geometric volume.

Valore riferito al volume d'aria contenuto nel silo.

(2) Weight referred to Cement bulk density of 1.4 Ton/m³.

Valore riferito a cemento a densità 1,4 Ton/m³.

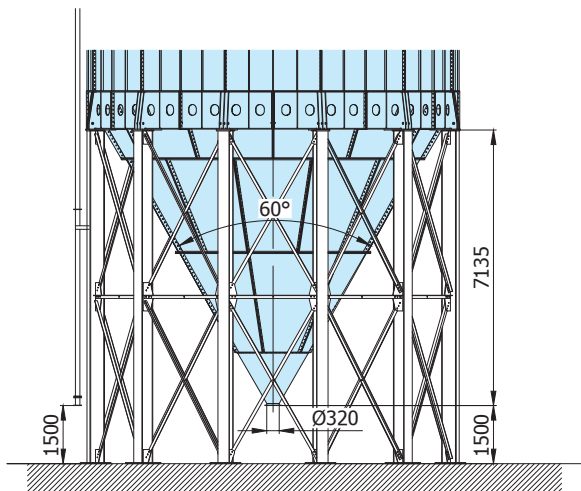
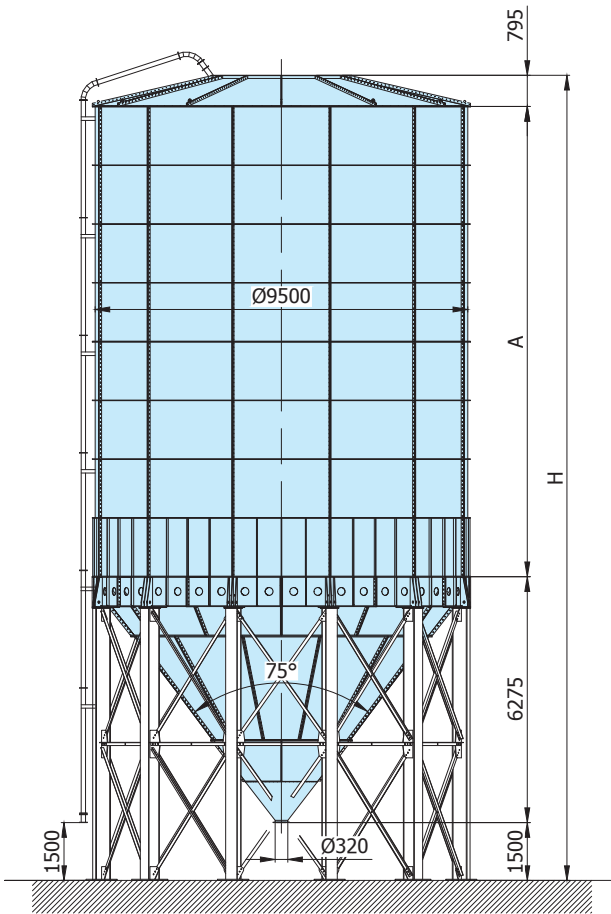

PANELED SILOS

Silos in Pannelli

Ø 12.500 mm SP SERIES - SERIE SP

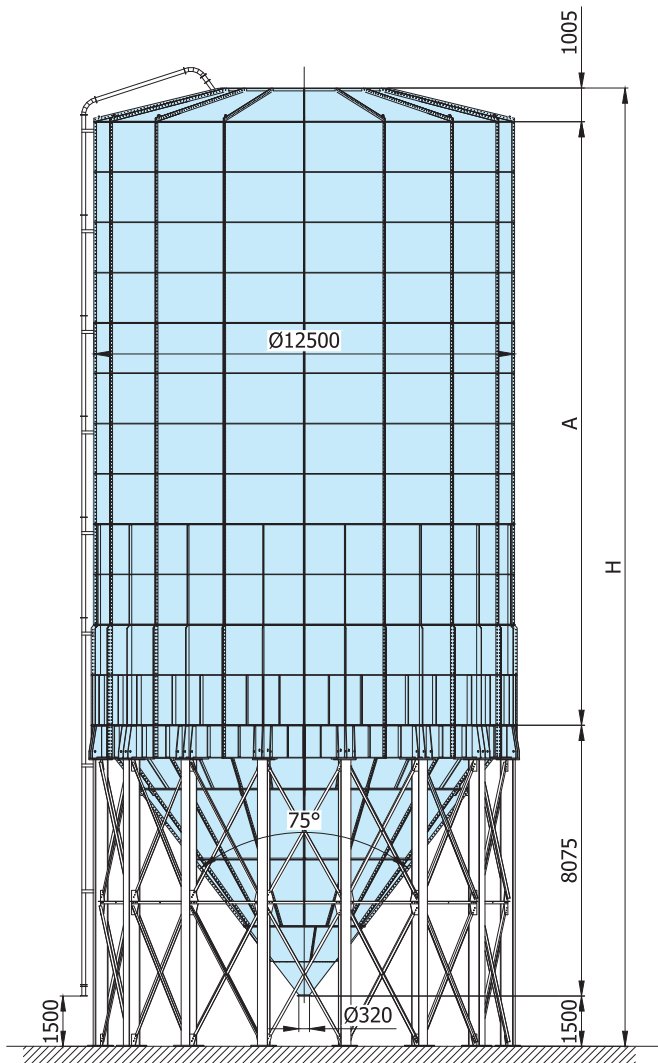

DIMENSIONS - DIMENSIONE (mm)

TYPE	m3 ⁽¹⁾	Ton ⁽²⁾	A	H
SP 1800	1800	2520	12000	22770
SP 2000	2000	2800	13500	24270
SP 2200	2200	3080	15000	25770
SP 2400	2400	3360	16500	27270
SP 2600	2600	3640	18000	28770
SP 2800	2800	3900	19500	30080
SP 3000	3000	4200	21000	31580

- (1) Capacity is referred to silo's geometric volume.
Valore riferito al volume d'aria contenuto nel silo.
- (2) Weight referred to Cement bulk density of 1.4 Ton/m³.
Valore riferito a cemento a densità 1,4 Ton/m³.





STORAGE TERMINAL

Terminal Stoccaggio



Flat Storage Terminal HC

The Flat Terminal has been designed for the storage of dry powders in harbors, where the foundation slab is already built or in those areas where the building height is restricted. Its rectangular design of bolted panels configures the HC silo unit of 1400 m³ of capacity, which can be replicated as many times as the client wishes to install rectangular silos with larger capacity.

During the silos' filling, the vessel or the mobile pumping unit, is connected to the filling pipeline and starts pumping the cement into the silos. If more than one silo has been installed, the operator may choose which silo is going to be loaded first thanks to a diverter valve system. As soon as the cement reach the bottom of the silos, it is possible to start the extraction from the silo, even during the filling process. The extraction is done by a screw conveyor system, and a loading bellow, directly into tank lorries.

Terminal di Stoccaggio Tipo HC

Il Terminal di stoccaggio orizzontale è un impianto progettato per il ricevimento, l'immagazzinamento e la distribuzione di cemento sfuso o di prodotti polverosi in genere. L'impianto è composto da più sili HC con capacità di 1400 m³ che grazie alla loro forma costruttiva; compatta modulare e amovibile banchine portuali o all'interno di fabbricati.

Nella fase di riempimento dei silos la nave cementiera (o un gruppo pompante mobile), si collega alla linea di carico del Terminal e inizia a pompare il prodotto alternativamente nell'uno o nell'altro silo. E' possibile determinare in quale dei silos inviare il prodotto grazie a delle valvole deviatrici esistenti poste lungo la tubazione.

Non appena il cemento raggiunge il livello di riempimento delle tramogge, è già possibile iniziare l'estrazione del prodotto mentre la nave continua a riempire.

L'estrazione del prodotto è effettuata mediante delle coclee estrattrici le quali caricano le autocisterne per mezzo di uno scaricatore telescopico.





Flat Storage Terminal HC

Terminal di Stoccaggio Tipo HC

Advantages

- *Good ratio in terms of investment / volume stored.*
- *Comply with the most restrictive regulations of harbors' agencies for trading and industrial installations.*
- *Not big civil works are needed thanks to the uniform distribution of loads over the ground.*
- *Overall Height doesn't exceed 14 meters.*
- *The modular design allows future expansion.*
- *The structure is movable. It is easy to install and disassemble.*
- *No pollution. A de-dusting system grants that no dust is emitted to the environment during loading / unloading operations.*
- *Low installation and operating cost thanks to a very simple engineering process that does not require qualified workers.*

Vantaggi:

- Un buon rapporto tra investimento e quantità di prodotto stoccato.
- Le dimensioni molto compatte agevolano l'individuazione del sito d'installazione e garantiscono l'esito positivo nella valutazione d'impatto ambientale.
- La facilità di montaggio e smontaggio facilitano la concessione dell'installazione da parte delle autorità competenti.
- La modularità dell'impianto permette futuri ampliamenti.
- Un rapporto molto basso di distribuzione del carico in kg/cm², grazie a un gran numero d'appoggi, permette l'installazione del Terminal su una soletta in calcestruzzo e fa sì che il Terminal sia posizionabile su qualsiasi banchina portuale.
- Logica d'impianto molto semplice, tale da consentire l'impiego del Terminal anche da parte di personale generico e assicurare costi di gestione irrisori.



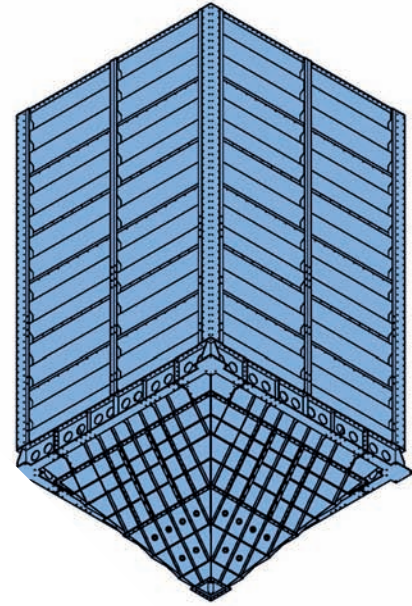
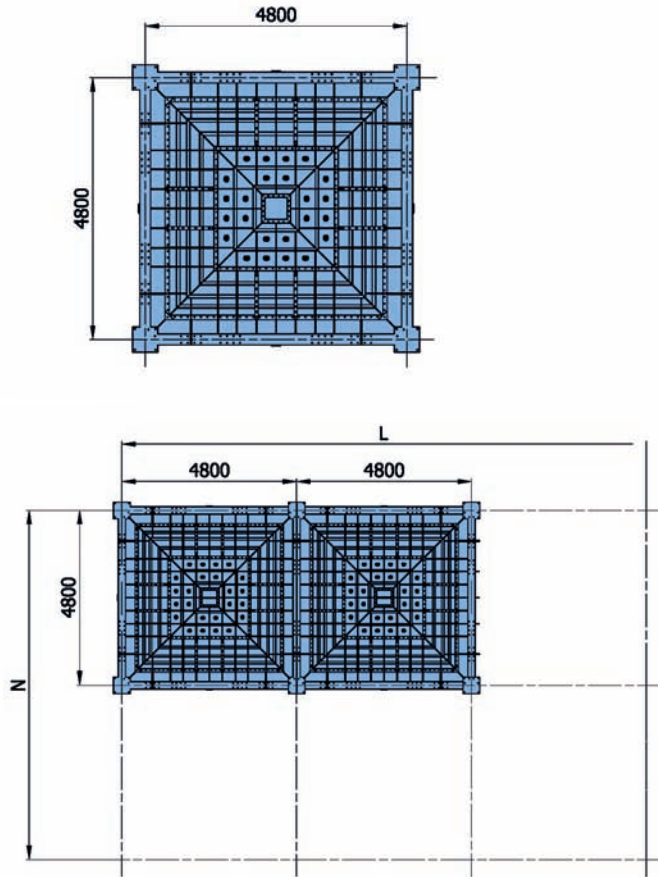

EXPANDABLE MODULE
MODULO ESPANDIBILE



2

Intermediate hanger bearing standart type
Supporto intermedio standard

Heavy duty hanger bearing
Supporto intermedio esecuzione pesante

Heavy duty hanger bearing flanged type
Supporto intermedio flangiato

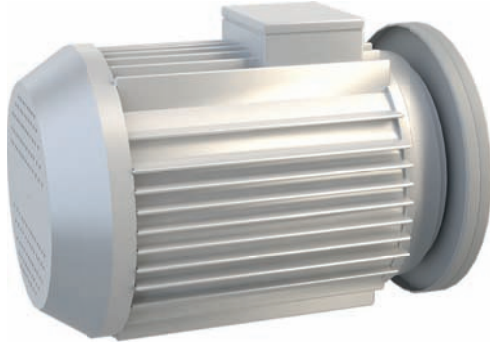

1

Unit Drive. Chain drive or pulley drive, available on demand

Motoriduttore. Trasmissione a catena o a pulegge disponibile su richiesta

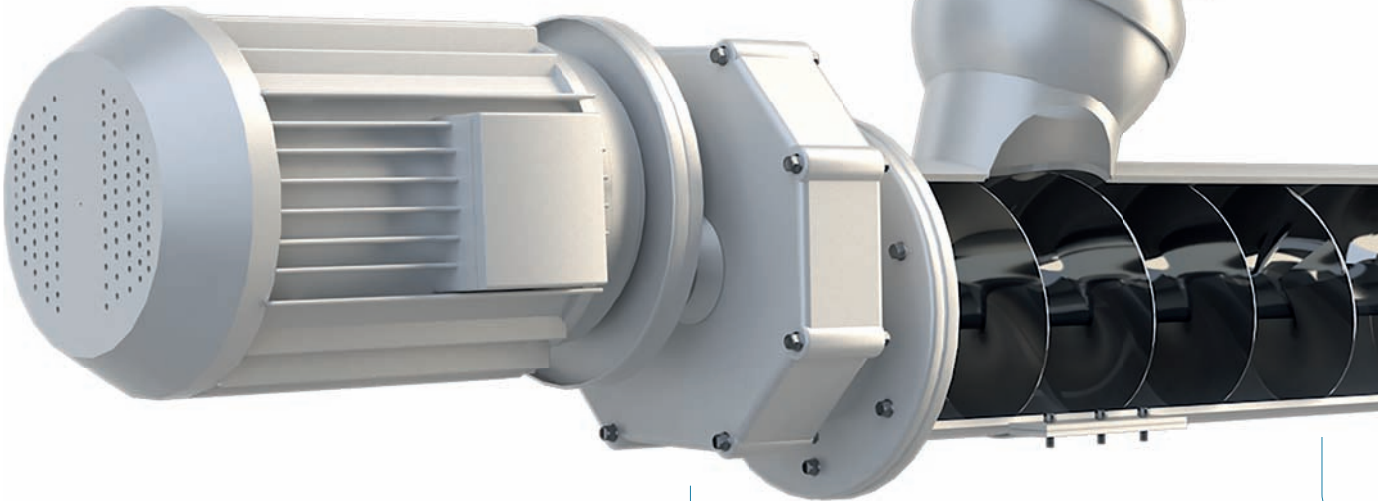

4

Direct gearbox with helicoids teeth

Riduttore di velocità ad accoppiamento diretto con ingranaggi a dentatura elicoidale rettificati





3

Thrust race end bearing standard or Heavy duty type
Supporto folle di coda tipo standard o robusto



7

Rotation control sensor available on demand
Sensore di controllo della rotazione disponibile su richiesta

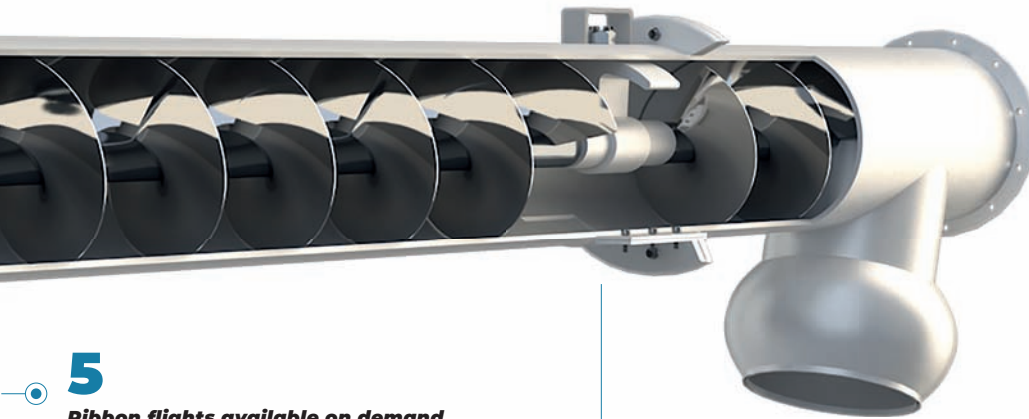

5

Ribbon flights available on demand
Spirale ribbon disponibile su richiesta



Creusabro sectional flight available on demand
Spirale a settori in Creusabro antiusura disponibile su richiesta

6

Plug design inspection door
Portina d'ispezione a ripristino di sezione

1



2



3



4



5



6



7



SCREW CONVEYORS

Coclee Trasportatrici

YORS



Screw Conveyors *Coclee Trasportatrici*

Transporting powdered materials has always been the main problem of whoever operates in the cement industry field; therefore, the primary scope of SCUTTI S.R.L. is to provide its customers with the right solution to this problem. SCUTTI S.R.L. offers a wide range of screw conveyors that are able to satisfy the strictest requirements, both in performance and in reliability.

Scutti's screw conveyors are at the same time practical, efficient, easy maintenance, pollution-free, and above all, economical.

The experience that Scutti have achieved operating around the world over the years, allow our engineering staff to provide our customers with the most effective solution to each specific application.

The attention paid to the customer's satisfaction BEFORE, DURING and AFTER sale, makes SCUTTI S.R.L. the ideal partner of every operator.

Il trasporto di materiali in polvere è sempre stato il problema principale di chi opera nel settore dell'industria del cemento; pertanto, lo scopo principale di SCUTTI è fornire ai propri clienti la giusta soluzione a questo problema.

SCUTTI offre una vasta gamma di trasportatori a coclea in grado di soddisfare le più severe esigenze, sia in termini di prestazioni che di affidabilità. I trasportatori a coclea di Scutti sono al tempo stesso pratici, efficienti, di facile manutenzione, privi di inquinamento e, soprattutto, economici.

L'esperienza acquisita da Scutti negli anni ha permesso al nostro staff tecnico di fornire ai nostri clienti la soluzione più efficace per ogni specifica applicazione.

L'attenzione prestata alla soddisfazione del cliente PRIMA, DURANTE e DOPO la vendita, rende SCUTTI SRL il partner ideale di ogni operatore.

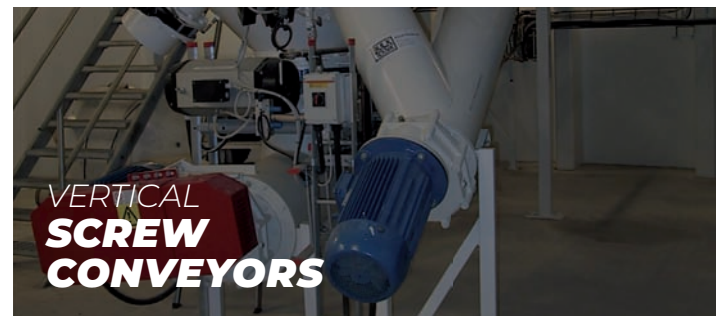
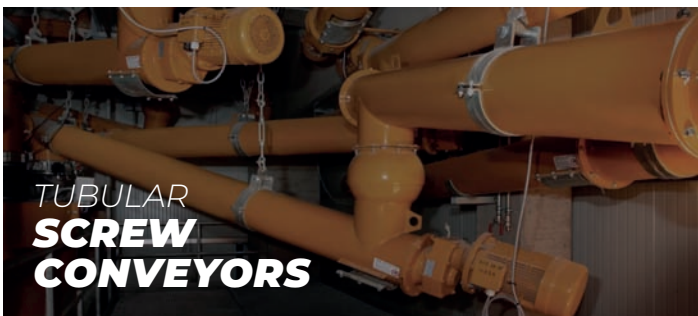

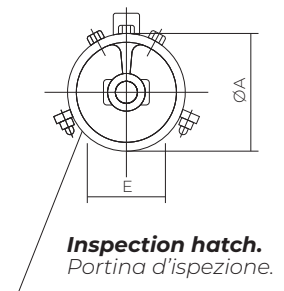
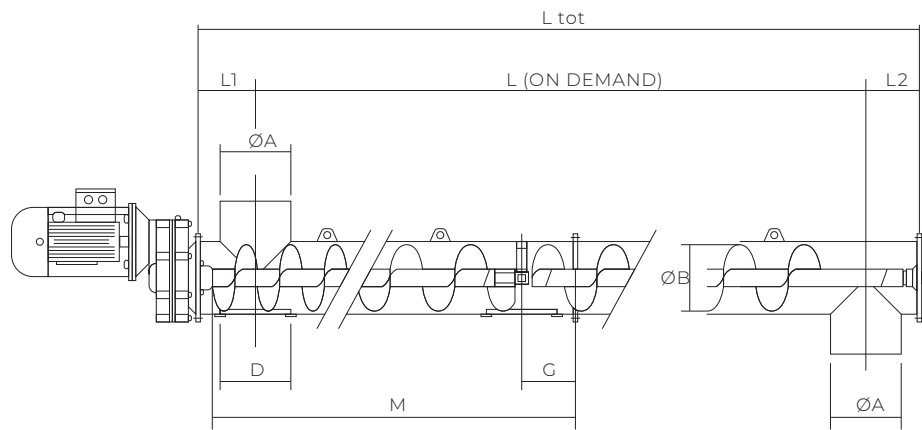

TUBULAR SCREW CONVEYORS CTS TYPE - COCLEE TUBOLARI SERIE CTS - DIM (mm)

TYPE	ØA	ØB	D	E	G	M	L	L1	L2	Ltot
CTS 114	114	90	180	90	200	3000	OND DEMAND	150	130	L+L1+L2
CTS 139	139	120	180	90	200	3000	OND DEMAND	170	150	L+L1+L2
CTS 168	168	140	245	125	200	3000	OND DEMAND	185	165	L+L1+L2
CTS 193	193	170	245	125	200	3000	OND DEMAND	200	180	L+L1+L2
CTS 219	219	190	245	160	200	3000	OND DEMAND	200	180	L+L1+L2
CTS 273	273	240	245	170	200	3000	OND DEMAND	235	215	L+L1+L2
CTS 323	323	300	245	200	240	3500	OND DEMAND	260	240	L+L1+L2

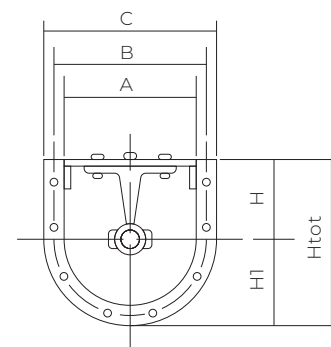
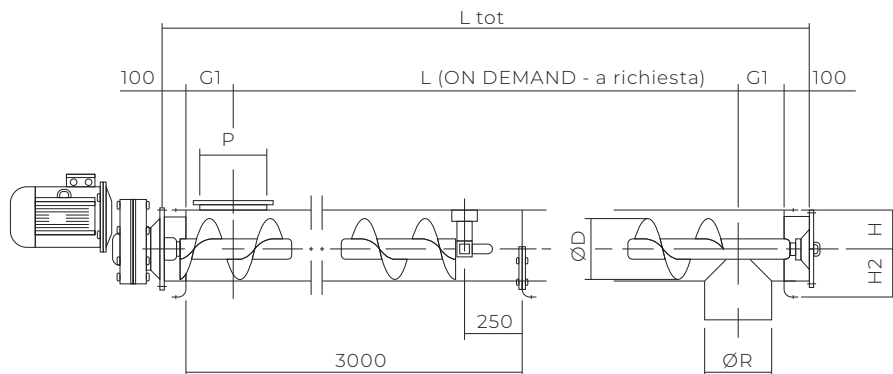

U TROUGH SCREW CONVEYORS CNU TYPE - COCLEE A CANALA SERIE CNU - DIM (mm)

TYPE	A	B	C	ØD	G1	H	H1	H2	Htot	P	ØR	L	Ltot
CNU 150	174	228	260	150	155	120	130	175	250	87X87	168	OND DEMAND	L+2XG1+200
CNU 200	224	278	310	200	180	140	155	200	295	112X112	219	OND DEMAND	L+2XG1+200
CNU 250	276	330	362	250	200	165	181	225	346	138X138	273	OND DEMAND	L+2XG1+200
CNU 300	324	382	422	300	230	200	211	250	411	162X162	323	OND DEMAND	L+2XG1+200
CNU 350	378	436	476	350	260	240	238	300	478	189X189	407	OND DEMAND	L+2XG1+200



www.scuttinicola.com

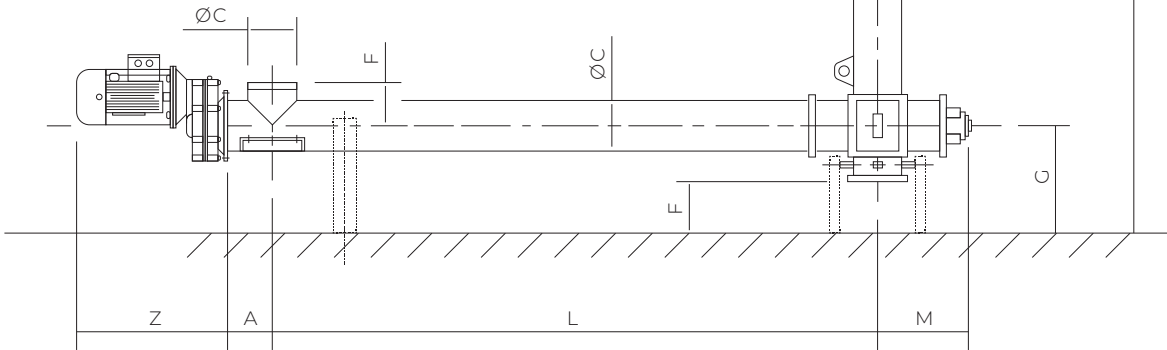
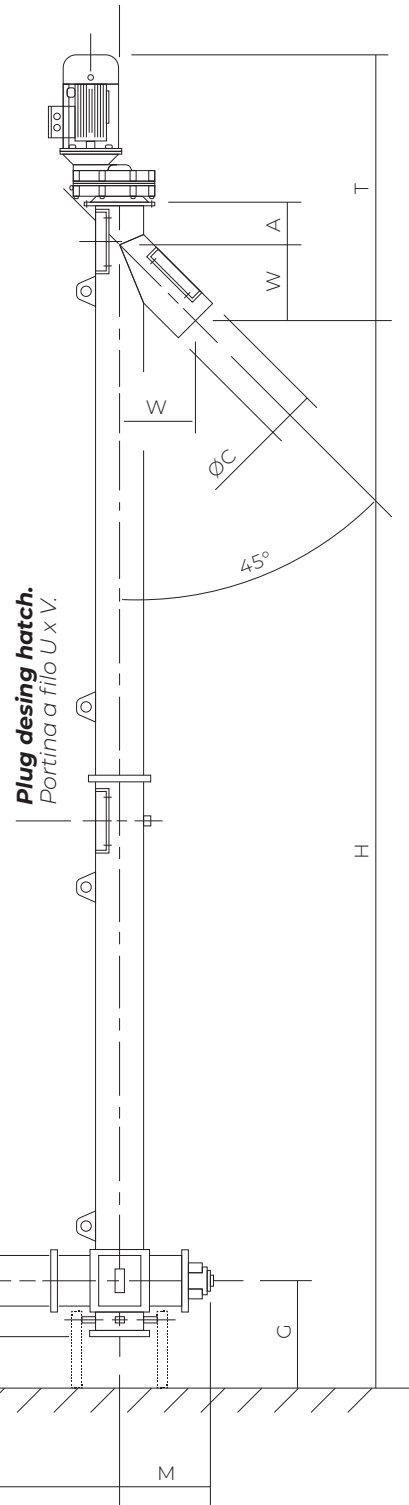

VERTICAL SCREW CONVEYORS CVS TYPE – COCLEE VERTICALI SERIE CVS – DIM (mm)

ØC	A	L	M	E	F	G	H	W	U x V	T	Z
114	150	VAR. OND DEMAND MIN 800	330	120	150	350	VAR. OND DEMAND	215	155 x 90	VAR. MAX. 1040	VAR. MAX. 515
139	170	VAR. OND DEMAND MIN 800	330	130	150	350	VAR. OND DEMAND	215	155 x 90	VAR. MAX. 1040	VAR. MAX. 515
168	185	VAR. OND DEMAND MIN 1500	460	160	200	440	VAR. OND DEMAND	285	205 x 125	VAR. MAX. 1390	VAR. MAX. 690
193	200	VAR. OND DEMAND MIN 1500	460	175	200	440	VAR. OND DEMAND	285	205 x 125	VAR. MAX. 1390	VAR. MAX. 690
219	200	VAR. OND DEMAND MIN 1500	520	190	200	500	VAR. OND DEMAND	355	205 x 160	VAR. MAX. 1390	VAR. MAX. 690
273	235	VAR. OND DEMAND MIN 2000	520	215	200	550	VAR. OND DEMAND	355	205 x 160	VAR. MAX. 1600	VAR. MAX. 890
323	260	VAR. OND DEMAND MIN 2000	670	240	200	550	VAR. OND DEMAND	355	255 x 200	VAR. MAX. 1600	VAR. MAX. 890



FILTERS
Filtri



MAXAIR (24 m²).

AIR JET CLEANING

Filtro depolveratore.

Round cartridge filter supplied with 24 m² filtering surface and air jet cleaning system; it's designed to be installed on top of silos as a vent filter. Minimum dimensions and quick opening devices allow full safety and trouble-free maintenance for the operator. The MAXAIR filter is available with dust collecting hopper and butterfly valve.

MAXAIR-24 è un filtro depolveratore a cartucce destinato ad essere installato sulla sommità dei silos. Ridottissimo ingombro e dispositivi ad apertura rapida sono stati studiati per consentire all'operatore di eseguire la manutenzione del filtro in tutta sicurezza, velocemente e comodamente.

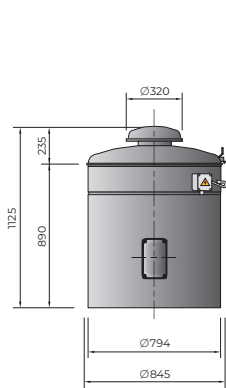

Dimension in operation
Dimensioni durante il funzionamento

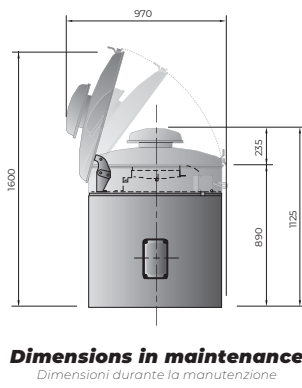

Dimensions in maintenance
Dimensioni durante la manutenzione

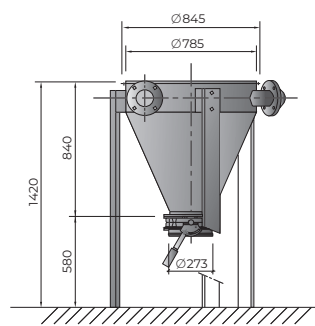

Dust collector
Raccogliitore di polvere

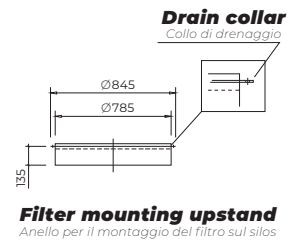

Filter mounting upstand
Anello per il montaggio del filtro sui silos



FGS (9 a 39 m²). AIR JET CLEANING

Filtro depolveratore.

Round cartridge filters available from 9 to 39 m² filtering surface, with air jet cleaning system. The FGS filter is made of stainless steel and it is available with dust collecting hopper with butterfly valve and electric fan.

Filtri a cartucce dotati di sistema di pulizia automatico ad aria compressa disponibili in vari formati da 9 a 39 m² di superficie filtrante. È possibile configurare i filtri con tramoggia di raccolta ed elettroaspiratore.

Assembly with electric fan Esecuzione con aspiratore

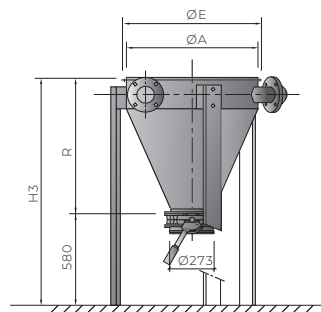
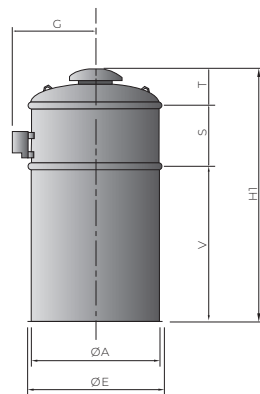
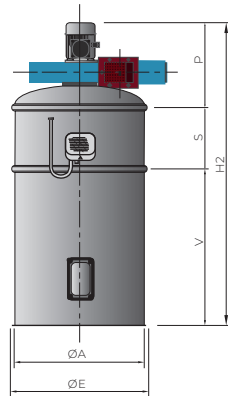

Dust collector
Tramoggia di raccolta polveri

Drain collar Collare di drenaggio

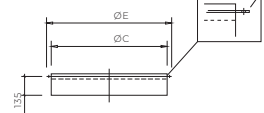

Filter mounting upstand
Anello sottofiltro a saldare

Assembly without electric fan Esecuzione senza aspiratore

DIMENSIONS - DIMENSIONI (mm)

MODEL	ØA	ØE	ØC	G	V	S	T	H1	P (max)	H2	R	H3
FGS/9	600	630	585	450	810	390	235	1435	540	1740	600	1180
FGS/11	600	630	585	450	960	390	235	1585	540	1890	600	1180
FGS/19	800	830	785	550	810	390	235	1435	545	1745	840	1420
FGS/23	800	830	785	550	960	390	235	1585	545	1895	840	1420
FGS/32	1000	1030	985	650	810	390	235	1435	640	1840	840	1420
FGS/39	1000	1030	985	650	960	390	235	1585	640	1990	840	1420



FGV (20 a 37 m²). AIR JET CLEANING

Filtro depolveratore.

Round cartridge filters available from 20 to 37 m², filtering surface with electric vibrator cleaning system. The FGV filter is made of stainless steel and it is available with dust collecting hopper with butterfly valve and electric fan.

Filtri circolari a cartucce dotati di sistema di pulizia a scuotimento mediante moto vibratore elettrico sono disponibili in vari formati da 20 a 37 m² di superficie filtrante. È possibile configurare i filtri con tramoggia di raccolta ed elettroaspiratore.

Assembly with electric fan

Esecuzione con aspiratore

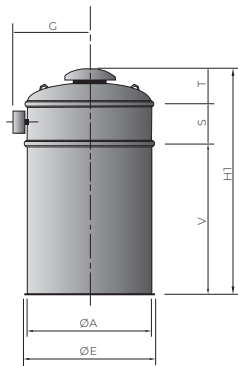
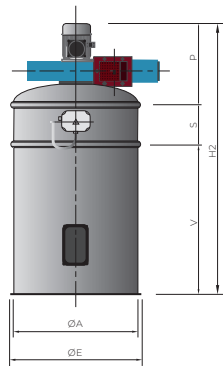

Assembly without electric fan

Esecuzione senza aspiratore

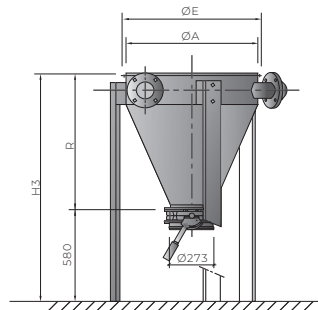

Dust collector

Tramoggia di raccolta polveri

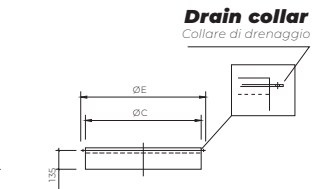

Filter mounting upstand

Anello sottofiltro a saldare

DIMENSIONS - DIMENSIONI (mm)

MODEL	ØA	ØE	ØC	G	V	S	T	H1	P (max)	H2	R	H3
FGV.20	800	845	785	450	810	210	235	1255	545	1565	840	1420
FGV.24	800	845	785	450	960	210	235	1405	545	1715	840	1420
FGV.31	1000	1030	985	550	810	210	235	1255	640	1660	840	1420
FGV.38	1000	1030	985	550	960	210	235	1405	640	1810	840	1420

EKO (50,72 a 86 m²).

AIR JET CLEANING

Filtro depolveratore.

Rectangular cartridge filter supplied in 3 different sizes 50, 72, 86 m² filtering surface, made of mild steel and full immersion air jet cleaning system. EKO filter is designed for dust collection during the loading procedure of the truck mixer and also to be installed on top of silos as a vent filter; as a loading area filter, it is equipped with a dust collecting hopper, butterfly valve, maintenance door and electric fan.

Filtro depolveratore di grandi capacità dotato di sistema di pulizia automatico ad aria compressa con sistema full immersion disponibile nei formati da 50, 72 e 86 m². Particolarmente adatto alla filtrazione delle polveri dovute al carico delle autobetoniere si adatta a diversi settori. Il filtro è costruito in acciaio al carbonio in esecuzione verniciata ed è provvisto di portello di manutenzione tramoggia di raccolta ed elettroaspiratore.

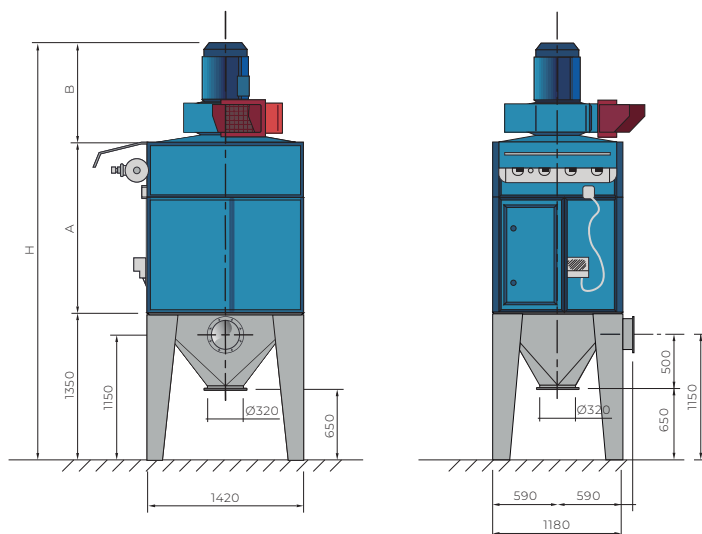
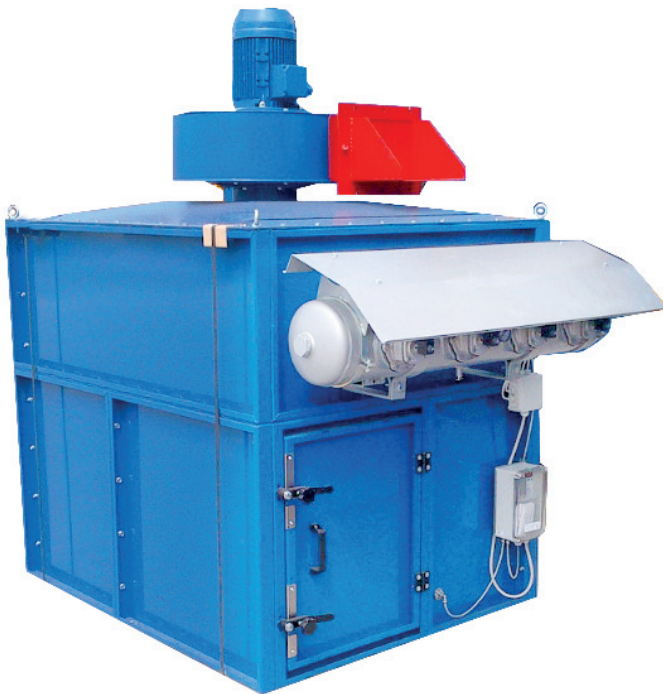

Assembly EKO with electric fan

Esecuzione EKO con aspirazione

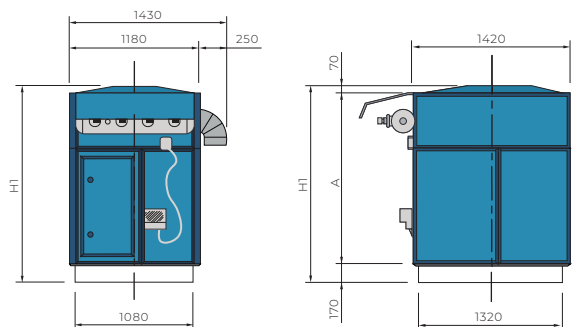

Assembly EKO BO model without electric fan

Esecuzione EKO BO senza aspirazione

DIMENSIONS - DIMENSIONI (mm)				
MODEL	A	B (max)	H	H1
EKO.50.A	1260	740	3350	
EKO.50.B0	1260			1500
EKO.72.A	1560	900	3810	
EKO.73.B0	1560			1800
EKO.86.A	1760	900	4010	
EKO.86.B0	1760			2000



FGM (5 a 15 m²). AIR JET CLEANING

Filtro depolveratore.

Round bag filters supplied from 9 to 15 m² filtering surface with air jet cleaning system. The FGM filter is made of stainless steel and it is available with a dust collecting hopper with butterfly valve and electric fan.

Filtri a maniche dotati di sistema di pulizia automatico ad aria compressa disponibili in vari formati da 9 a 15 m² di superficie filtrante. È possibile configurare i filtri con tramoggia di raccolta ed elettroaspiratore.

Assembly with electric fan

Esecuzione con aspiratore

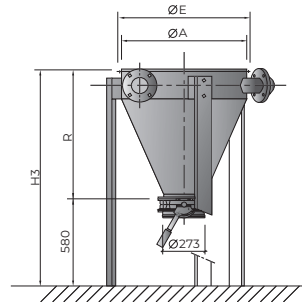
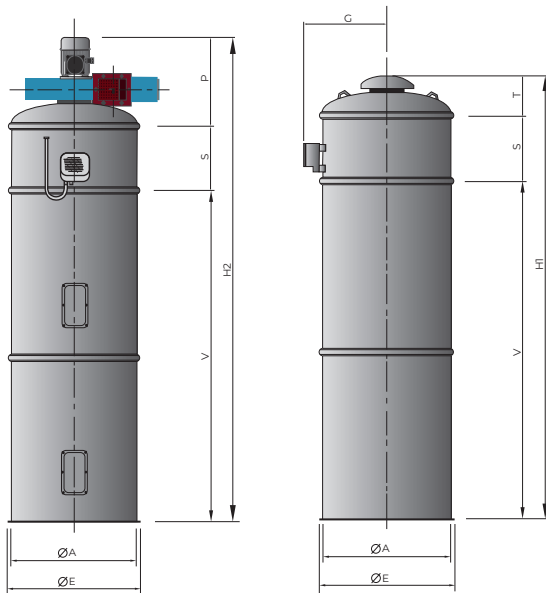

Dust collector
Tramoggia di raccolta polveri

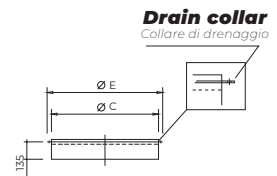

Filter mounting upstand
Anello sottofiltro a saldare

Assembly without electric fan

Esecuzione con aspiratore

DIMENSIONS - DIMENSIONI (mm)

MODEL	ØA	ØE	ØC	G	V	S	T	H1	P _(max)	H2	R	H3
FGM.05	600	630	585	450	1620	390	235	2245	540	2550	600	1180
FGM.10	800	830	785	550	1620	390	235	2245	545	2550	840	1420
FGM.15	1000	1030	985	650	1620	390	235	2245	640	2650	840	1420



MINIDUST (2, 4 e 6 m²). AIR JET CLEANING

Sistema di pulizia ad aria.

Small cartridge filter available in three sizes 2,4,6 m² filtering surface; made of mild steel with air jet cleaning system. The compact design allows the installation of this filter on weight-hoppers or small tanks.

Filtro a cartuccia di piccole dimensioni disponibile in tre misure 2,4,6 m² di superficie filtrante; realizzato in acciaio al carbonio utilizza un sistema di pulizia a getto d'aria. Il design compatto consente l'installazione di questo filtro su tramogge pesatrici o piccoli serbatoi.

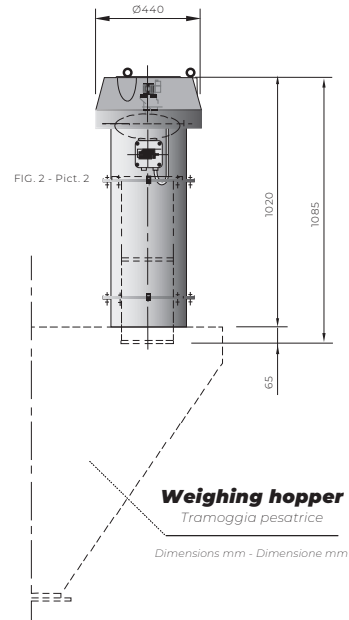
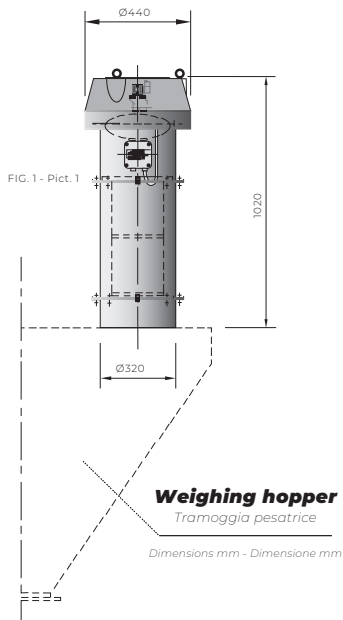

TECHNICAL SPECIFICATIONS - SPECIFICHE TECNICHE

MODEL	PICT	FILTER SURFACE (m ²)	CAPACITY (m ³ /h)
MINIDUST - 02	1	2	145
MINIDUST - 04	1	4	290
MINIDUST - 02	2	6	430



I.SLEEVE (35 a 127 m²).

AIR JET CLEANING

Sistema di pulizia pneumatico.

Large size baghouse dust filters suitable for the filtration of powders from various industrial processes. I.SLEEVE can be equipped with many accessories such as maintenance access ladder, handrailing, rotary valve and screw feeder.

Filtri a maniche di grandi capacità, sono adatti alla filtrazione di polveri derivanti da vari processi industriali.

Gli I.SLEEVE possono essere corredati di vari accessori come scala di manutenzione, ringhiera, valvola stellare e coclea di estrazione.

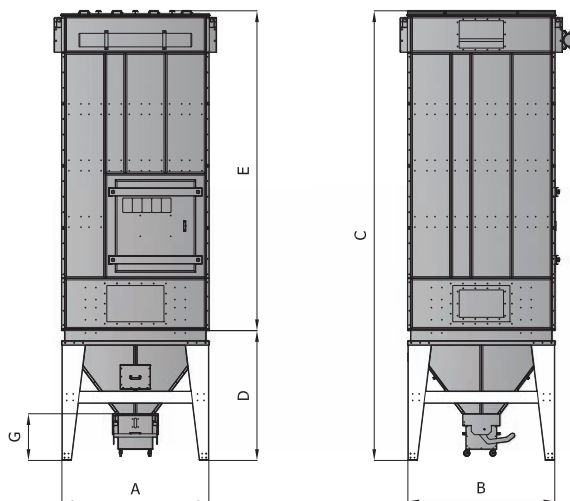

DIMENSIONS - DIMENSIONI (mm)

CODE MODEL	Filtering surface	A	B	C	D	E	F	G
I.SLEEVE. 35	35 m ²	1330	1330	4800	1400	3450	350	550
I.SLEEVE. 42	42 m ²	1330	1330	5350	1400	3950	350	550
I.SLEEVE. 53	53 m ²	1830	1330	5050	1650	3450	350	550
I.SLEEVE. 63	63 m ²	1830	1330	5600	1650	3950	350	550
I.SLEEVE. 79	79 m ²	1830	1830	5050	1650	3450	350	550
I.SLEEVE. 95	95 m ²	1830	1830	5600	1650	3950	350	550
I.SLEEVE. 105	105 m ²	2330	1830	5300	1900	3450	350	550
I.SLEEVE. 127	127 m ²	2330	1830	5850	1900	3950	350	550



SILO SAFETY SYSTEM

Sistema di sicurezza WicomSilo

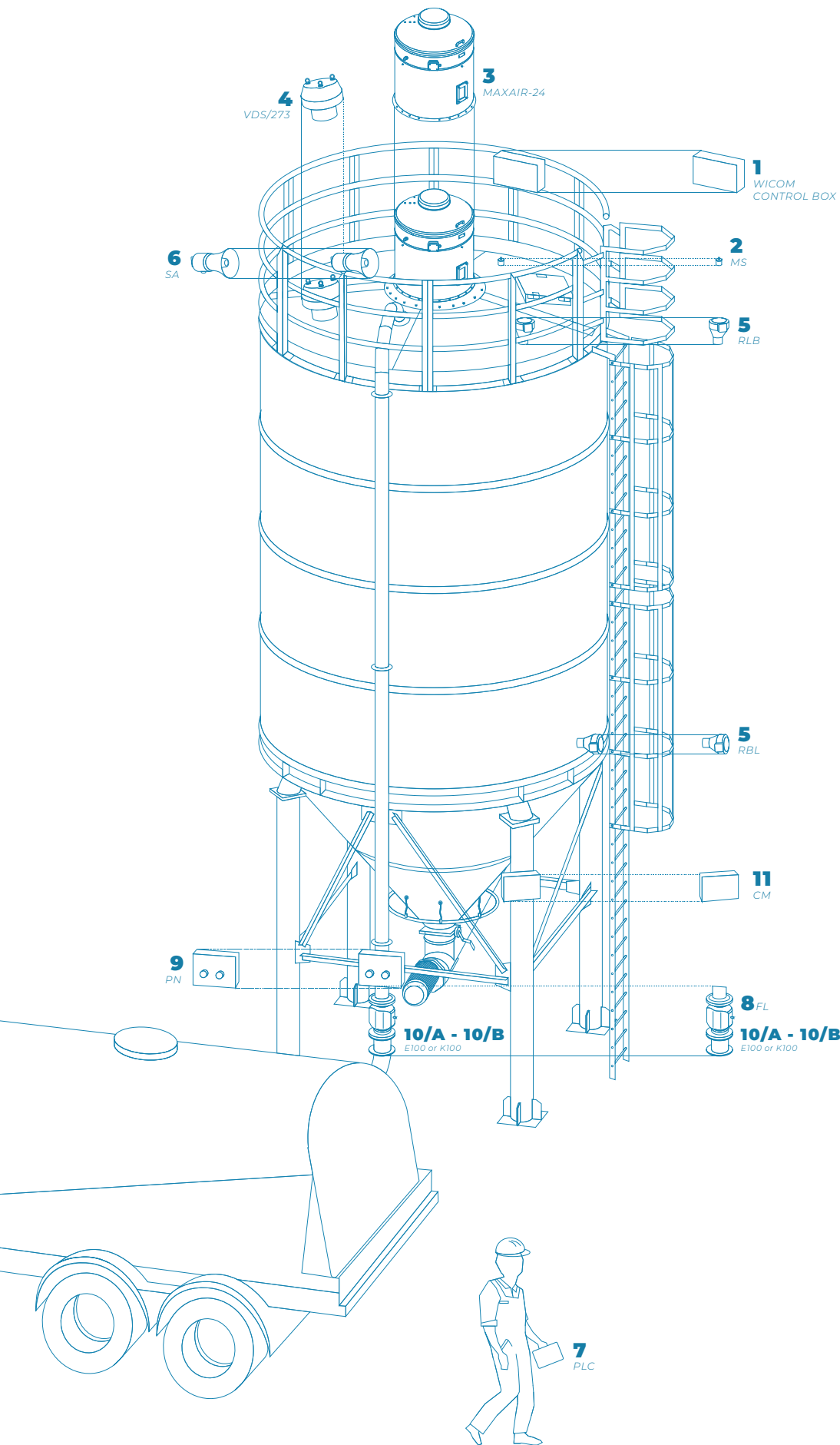

1 WICOM CONTROL BOX

The WICOM control box checks the air pressure into the silo and interacts with several safety devices.

La centralina WICOMBOX controlla la pressione interna del silo ed interagisce con i dispositivi di sicurezza che compongono il sistema.



5 RLB

The RLB level indicator, detects and displays via a light signal, that the product has reached the maximum and minimum level in the silo.

L'indicatore di livello RLB è un dispositivo elettromeccanico che indica la soglia di minimo e di massimo del prodotto contenuto nel silo.



9 PN

The PN pneumatic box contains the fittings to connect the pinch valve and the AIR pressure switch.

La cassetta pneumatica PN contiene i collegamenti pneumatici necessari per la valvola a manicotto ed il pressostato.

It is possible to manage up to 30 silos with a single PLC VISUAL.
Si possono gestire fino a 30 silo con l'ausilio di un unico PLC VISUAL.



2
MS

The MS pneumatic hose is located on the silo's roof to connect WICOM control box to the inside of the silo through a Rilsan pipe.

Il manicotto a saldare MS posizionato sul tetto del silo ha la sola funzione di collegare il silo al dispositivo WICOMBOX.



3
MAXAIR - 24

The de-dusting filter unit MAXAIR-24, is designed to collect and release into the silo the powder arising during the silo's filling.

Il Filtro MAXAIR-24 è un dispositivo di sfiato che raccoglie la polvere generata dal carico pneumatico evitando possibili emissioni in atmosfera.



4
VDS/273

The VDS/273 is a pressure relief valve, safety device that automatically opens in case of the internal pressure exceeds the design rate.

La valvola VDS/273 è un dispositivo meccanico che apre automaticamente quando la pressione interna del silo eccede i valori di taratura.



6
SA

The SA hooter, is a safety device which gives an acoustic warning when an anomaly occurs in the safety system.

La sirena di allarme SA si aziona automaticamente quando il sistema riscontra delle anomalie.



7
PLC

VISUAL is a touch screen PLC which controls the WICOM control box, locally or via remote Access. The display is available in two sizes, 4 and 7 inches.

Il touch screen VISUAL collegato alla scheda WICOMBOX permette di interagire col sistema da remoto. Display touch screen da 7 pollici.



8
FL

FL pinch valve, designed to close the filling line in case of emergency. Available in two sizes: DN80 and DN100.

La valvola a manicotto FL è un dispositivo di chiusura che viene azionato in caso di emergenza per interrompere il carico.



10/A
E100

The E100 adaptor ensures the connection between the tank lorry and the silo's fill pipe via a STORZ coupling. Available in two sizes: DN80 and DN100.

Il tronchetto di carico E100 attraverso un attacco STORZ connette il camion alla tubazione di carico del silo. Può essere fornito DN80 mm o DN100 mm.



10/B
K100

The K100 adaptor ensures the connection between the tank lorry and the silo's fill pipe via a PIN coupling. Available in two sizes: DN80 and DN100.

Il tronchetto di carico K100 attraverso un attacco a PERNI connette il camion alla tubazione di carico del silo. Può essere fornito DN80 mm o DN100 mm.

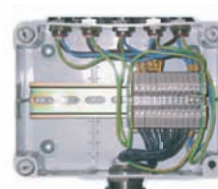

11
CM

The CM terminal box collects all the cables coming from the devices and connects to the WICOM control box via ONE cable only.

La morsetteria CM raccoglie i cavi delle varie utenze per uscire con un unico cavo multipolare verso la centralina WICOM.

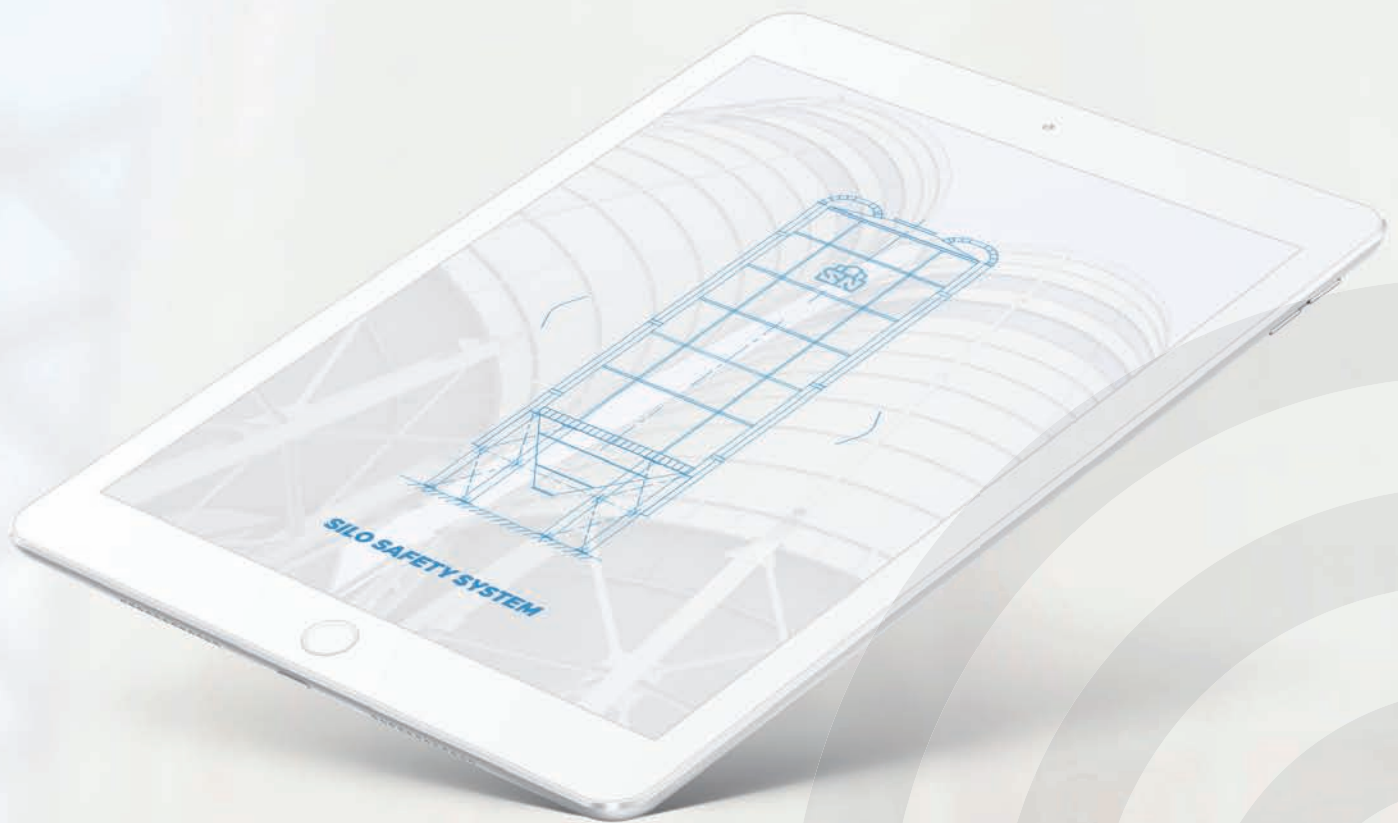

WICOMSILO

WEB BASED SILOS SAFETY SYSTEM

Sistema di sicurezza Silos accessibile da web



VALVES FOR HANDLING

Valvole di Intercettazione

VFA (Ø100 a Ø400 mm)

BUTTERFLY VALVES

Valvole a farfalla

Aluminum butterfly valve for handling powders available from Ø100 to Ø400 mm. The valve can be supplied for hot materials with manual lever or pneumatic actuator.

Valvola in alluminio per la regolazione del flusso di materiali poverosi. Disponibile con comando a leva o attuatore pneumatico nelle grandezze 100, 150, 200, 250, 300, 350, 400mm.

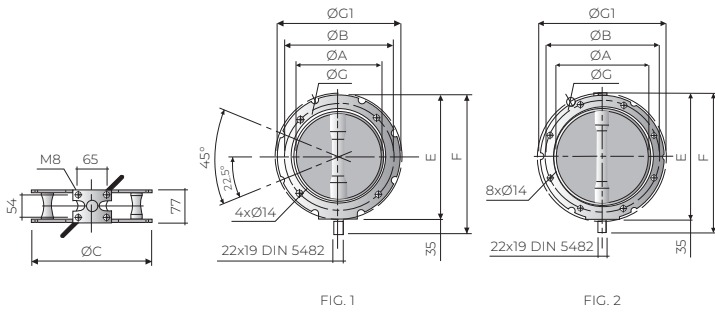

DIMENSIONS - DIMENSIONI (mm)

MODEL	ØA	ØB	ØC	E	F	ØG ⁽¹⁾	ØG1 ⁽¹⁾	kg.	FIG.
VFA - 100	100	180	220	183	222	220	4.5	1	
VFA - 150	150	200	228	283	272	18	228	5	1
VFA - 200	200	250	278	287	372	18	280	7	1
VFA - 250	250	300	328	337	372	18	385	8	2
VFA - 300	300	350	378	387	422	22	395	11	2

(1) UNI PN6

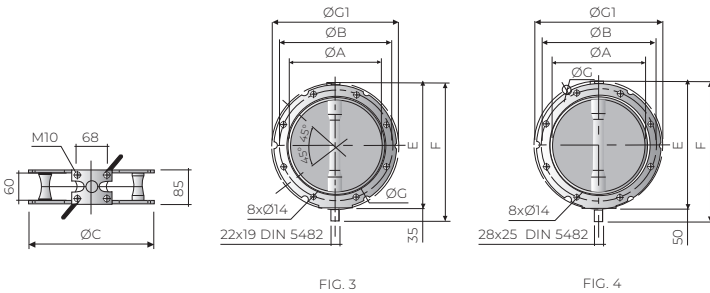

DIMENSIONS - DIMENSIONI (mm)

MODEL	ØA	ØB	ØC	E	F	ØG ⁽¹⁾	ØG1 ⁽¹⁾	kg.	FIG.
VFA - 350	350	400	440	439	489	22	445	20	3
VFA - 400	400	470	530	509	559	25	515	23	4

(1) UNI PN6

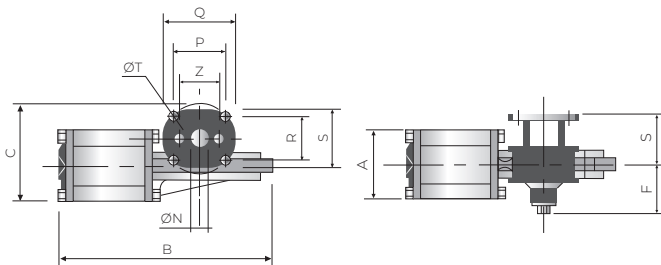
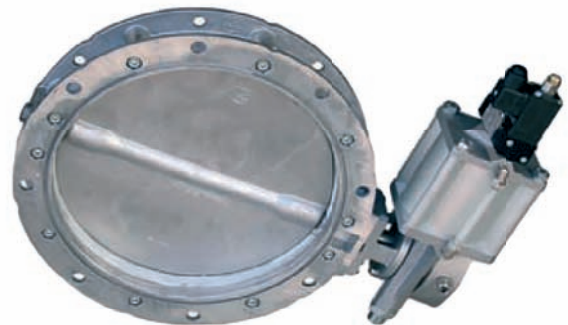

DIMENSIONS - DIMENSIONI (mm)

MODEL	A	B	C	F	ØN (DIN 5482)	P	Q	R	S	ØT	Z
CRP - 80	92	285	130	66	19X22	65	90	54	76	8.5	50
CRP - 100	112	295	140	66	19X22	65	90	54	76	8.5	50
CRP - 125	137	430	196	89	25X28	68	106	60	84	10.5	80

Pneumatic actuator

Attuatore pneumatico

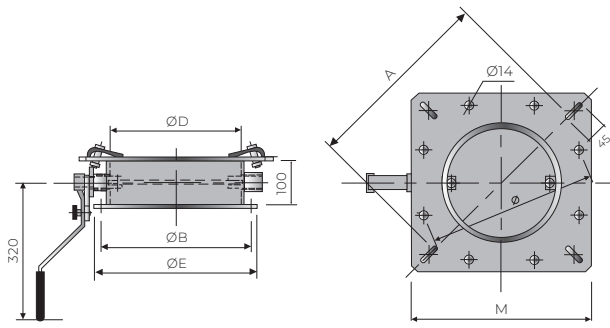

VFS

STEEL BUTTERFLY VALVES

Valvole a farfalla in acciaio

Mild steel butterfly valve for handling powders, commonly used as discharge valve under silos. It is recommended for heavy duty applications. The valve is supplied with manual lever only.

Valvola in acciaio al carbonio, normalmente applicata sotto lo scarico dei silos garantisce la tenuta di carichi ingenti di materiale.

DIMENSIONS - DIMENSIONI (mm)

MODEL	ØD	Øm	M	A	ØB	ØE
VFSQ2250	265	375	400	410	300	330
VFSQ2300	315	400	450	480	350	380

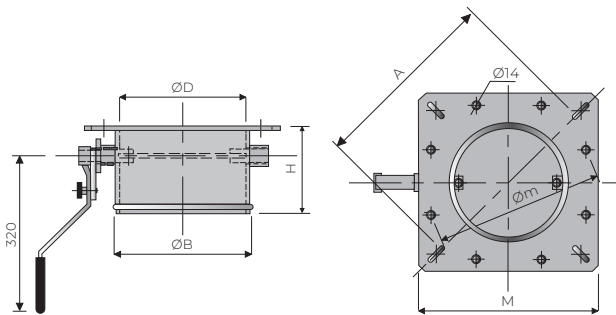

DIMENSIONS - DIMENSIONI (mm)

MODEL	ØA	Øm	ØB	M	A	H
VFSQ1250	265	375	273	400	410	180
VFSQ1300	315	400	323	450	480	195

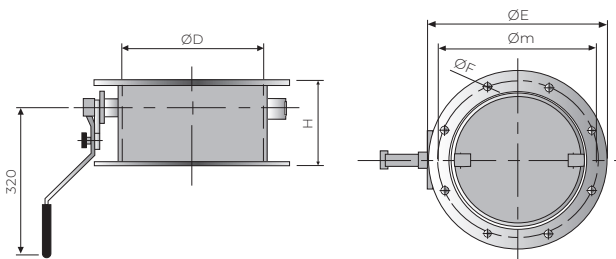
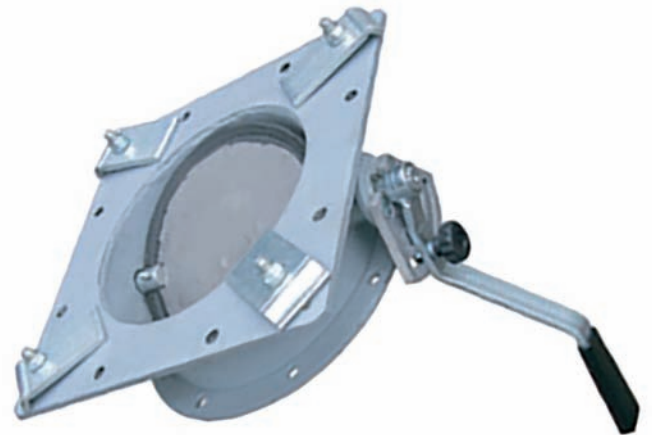

DIMENSIONS - DIMENSIONI (mm)

MODEL	ØD	Øm	ØE	H	ØF	N° Holes / Orif.
VFS 150	160	220	250	125	11	8
VFS 200	210	250	275	160	11	8
VFS 250	265	300	330	170	11	8
VFS 300	325	375	425	185	14	8
VFS 400	400	470	520	245	14	12



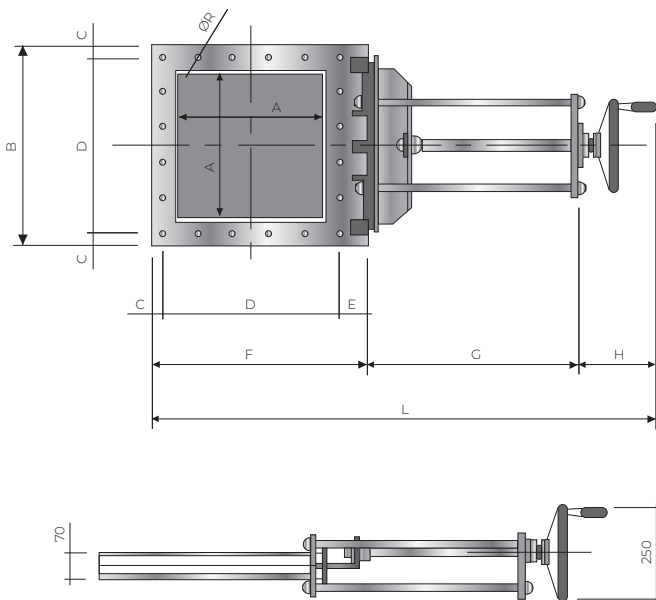

DIMENSIONS - DIMENSIONI (mm)

MODEL	A	B	C	D	E	F	G	L	ØR
VGS M250	250	358	20	3X106	70	408	390	998	M10
VGS M300	300	412	20	3X124	70	462	440	1102	M12
VGS M400	400	532	31	5X94	76	577	540	1317	M12

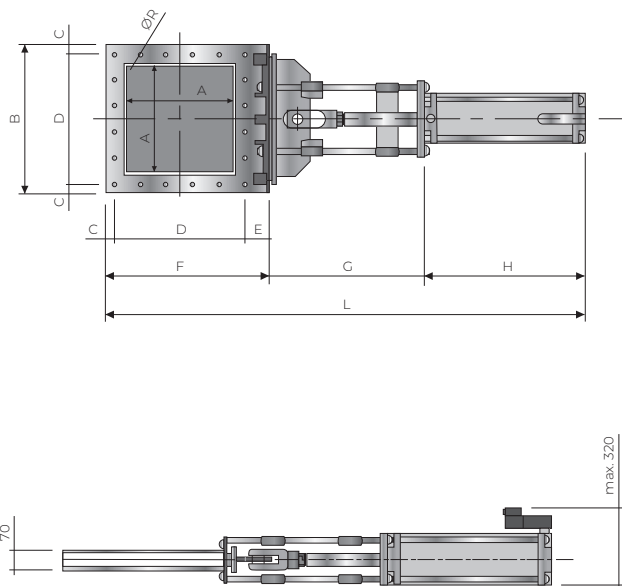

DIMENSIONS - DIMENSIONI (mm)

MODEL	A	B	C	D	E	F	G	H	L	ØR
VGS P250	250	358	20	3X106	70	408	580	430	1418	M10
VGS P300	300	412	20	3X124	70	462	630	480	1572	M12
VGS P400	400	532	31	5X94	76	577	730	580	1887	M12

VSG

SLIDE VALVES

Valvole a ghigliottina

Heavy duty slide valves made of cast iron for powders or granular products. This equipment ensures seal at high level for the external environment, and can be supplied in three sizes with manual wheel or with pneumatic actuator.

Valvola a ghigliottina serie pesante in ghisa. Particolarmente indicata per la regolazione di grossi carichi di materiale, grazie ad un sistema di tenuta a baderne registrabili garantisce la tenuta polveri.

Disponibile in tre grandezze con comando manuale o pneumatico.



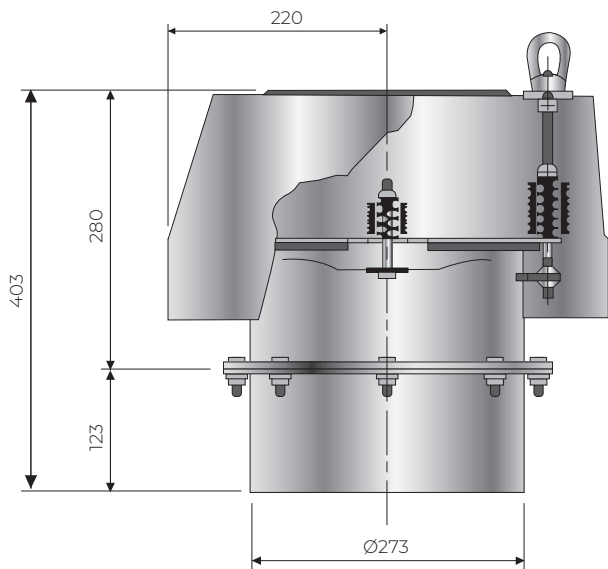

VDS

PRESSURE RELIEF VALVE

Valvola di controllo pressione

Pressure relief valves are designed to release the excess of pressure from the silo or to let air into the silo from the external environment during silo's filling, to preserve the silo's integrity. The valve is made of mild steel. On demand, can be supplied for hot products.

Valvola di controllo pressione, normalmente applicata sul silo consente in caso di anomalie di non sottoporre il contenitore a pressioni o depressioni.

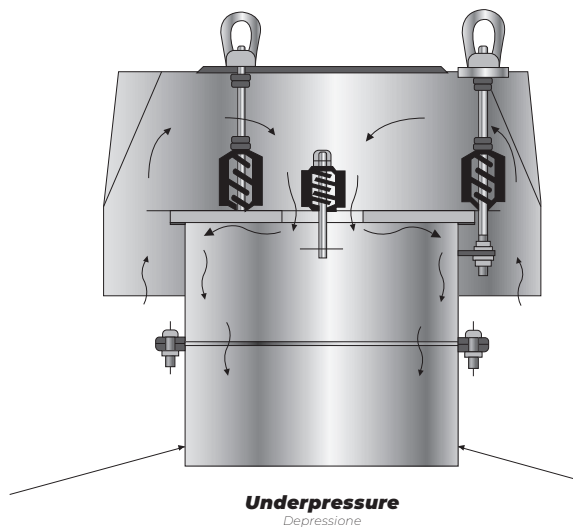
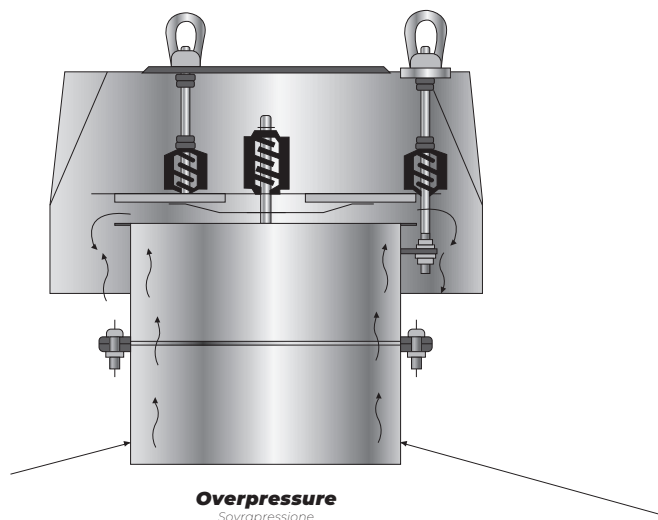



Vent filter.

Filtri di sfiato.



High efficiency dust collectors.

Filtri depolveratori ad alta efficienza.



Aeration system IF and PF on silo's cone.

Sistema di fluidificazione IF e PF sul cono di uscita del silo.



Detail of air blower.

Dettaglio soffiante.



Aeration pads Ø80 mm

Dischi fluidificanti Ø80 mm.



Detail of air slide.

Dettaglio canalina fluidificata.



Detail of pneumatic fill pipe.

Dettaglio tubazione di carico.



Silo with 3 outlets cone.

Silo con cono a 3 uscite.



Gantry structure for vehicles transiting.

Struttura a portale per passaggio camion.



Extraction via screw conveyors and loading bellow.

Estrazione a mezzo coclee trasportatrici.



Detail of mobile fill pipe.

Dettaglio tubazione di carico mobile.

ACCESORIE

ACCESORI



Mechanical pressure relief valve.

Valvola meccanica di sicurezza per controllo pressione.



Bladed level sensor.

Indicatori di livello paletta.



Radar level transmitter for continuous monitoring.

Indicatore di livello continuo tipo radar.



General control board.

Quadro elettrico generale.



Pumping station for compressed air.

Stazione di pompaggio aria compressa.



Hot dip galvanized stairways.

Esempio di scala a gradini zincata.



Detail of truck loading point.

Dettaglio punto carico autocisterne.



Detail of air slide aeration system.

Dettaglio fluidificazione a canaline.



Silo safety equipment.

Attrezzature di sicurezza per la salvaguardia dei silii.

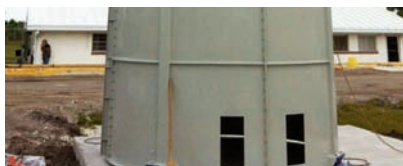

Self standing skirted.

Silo con gonna autoportante.

DRY BULK STORAGE AND HANDLING SOLUTIONS



SCUTTI SRL
C.da Vicenne 17, 66043 - Casoli (Ch) Italy

Tel. (+39) 0872.985249
Fax (+39) 0872.985117
info@scuttinicola.com

